

Loading Ribbon  
 碳帶安裝  
 碳帶安裝  
 Instalación de Cinta  
 Chargement du ruban  
 Laden des Druckbandes  
 Entrada de Filme  
 Caricamento Nastro  
 Ribon takma  
 Pasang Pita/Ribbon  
 تحميل الشريط

Loading Media  
 紙捲安裝  
 紙卷安裝  
 Instalación de Papel  
 Chargement de papier  
 Laden des Labelmaterials  
 Entrada de Papel  
 Caricamento Carta  
 Baskı malzemesini takma  
 Pasang Bahan/Media  
 تحميل الوسائط

Cutter Mode  
 裁刀模式  
 裁刀模式  
 Modo Cortar  
 Mode Couper  
 Schneidemodus  
 Modo Cortador  
 Modalità Taglierina  
 Kesme modu  
 Mode Pemotong  
 وضع القاطع

The user is cautioned that any changes or modifications which not recommended by Argox Information Co. Ltd. could result in the loss of the user's authority to operate the equipment. To ensure compliance, the users must use accessories and peripherals which approved by Argox Information Co. Ltd.



Supplemental Information: This device complies with the requirement of FCC Part 15 Rules. Operation is subject to the following two Conditions:  
 (1) This device may not cause harmful interference and  
 (2) this device must accept any interference received, including interference that may cause undesired operation.

**INDUSTRY CANADA NOTICE:**

This device complies with Industry Canada ICES-003 class A requirements. Cet équipement est conforme a ICES-003 classe A de la norm Industrielle Canadian.



The manufacturer declares under sole responsibility that this product conforms to the following standards or other normative documents:  
 EMC: EN 55022:2010, class A  
 EN 55024: 2010



Argox Information Co., Ltd certifies that the following products and/or components are compliant with the current requirements of the European Union Restriction on the use of Hazardous Substances (RoHS) Directive, 2011/65/EU.



**A급기기(업무용 방송통신기기)**  
 이 기기는 업무용(A급)으로 전자파적합등록을 한 기기이오니 판매자 또는 사용자는 이점을 주의하시기 바라며, 가정외의 지역에서 사용하는 것을 목적으로 합니다.

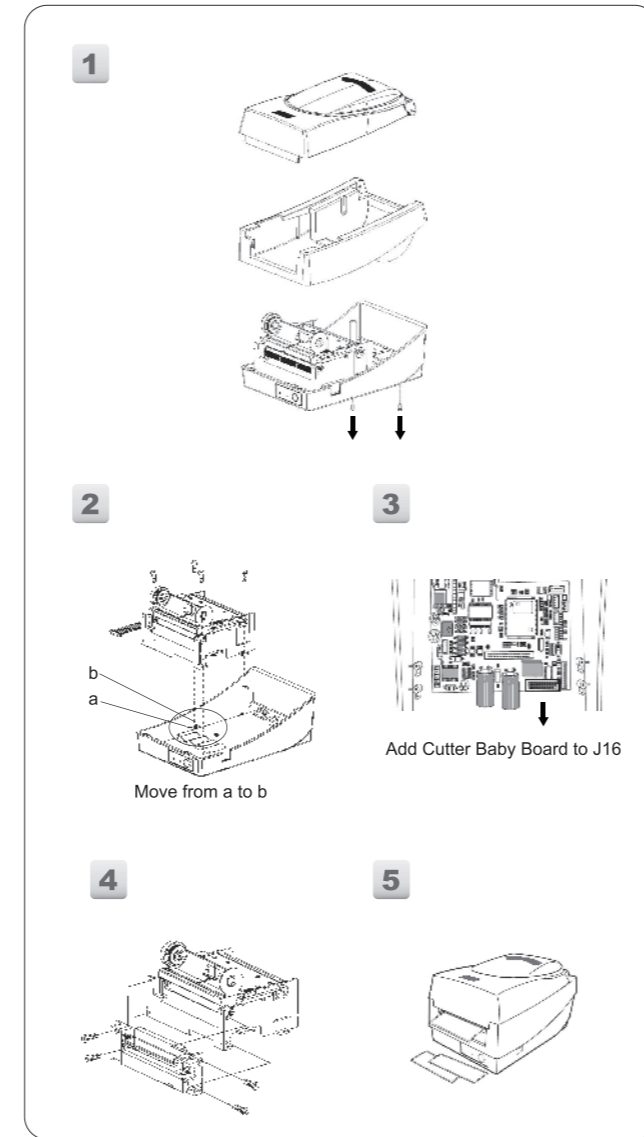
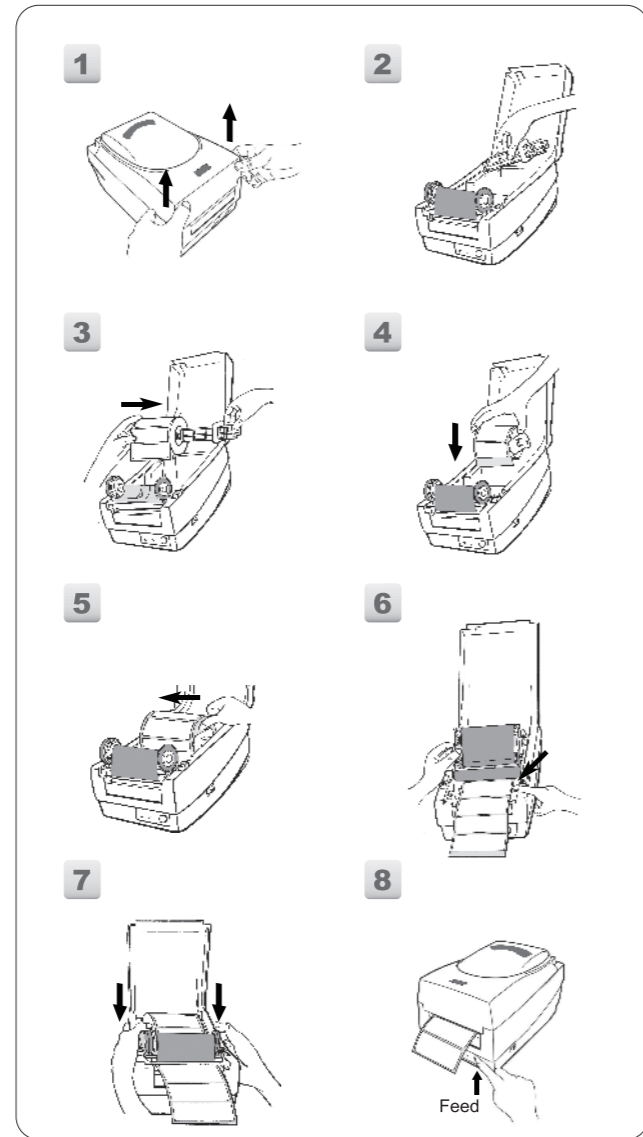
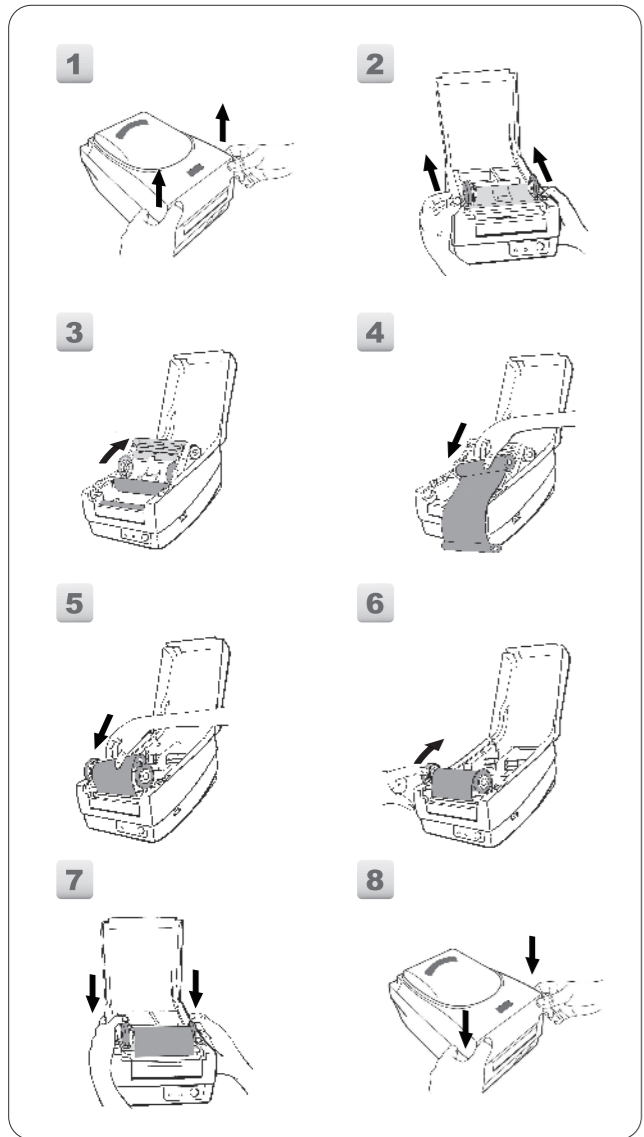

警告使用者:  
 這是甲類的資訊產品，在居住的環境中使用時，可能會造成射頻干擾，在這種情況下，使用者會被要求採取某些適當的對策。

**Argox Information Co., Ltd.**  
 7F., No.126, Ln.235, Baoqiao Rd., Xindian Dist., New Taipei City 231, Taiwan (R.O.C.)  
 Tel: +886-2-8912-1121 Fax: +886-2-8912-1124  
<https://www.argo.com>  
<https://www.youtube.com/user/argoxmtk>  
 email:service@argox.com  
 Copyright © 2019. Argox Information Co.Ltd., All Rights Reserved.

設備名稱 Equipment name	型號(型式): OS-214plus(系列型號如下) Type designation [Type]					
	限制物質及其化學符號 Restricted substances and its chemical symbols					
單元 Unit	鉛Lead (Pb)	汞Mercury (Hg)	鎘Cadmium (Cd)	六價鉻Hexavalent chromium (Cr <sup>6+</sup> )	多溴聯苯Polybrominated biphenyls (PBBs)	多溴二苯醚Polybrominated diphenyl ethers (PBDEs)
印刷電路板組件	-	○	○	○	○	○
機殼	-	○	○	○	○	○
線材	○	○	○	○	○	○
變壓器	-	○	○	○	○	○
印字頭模組	-	○	○	○	○	○

備考1: "超出0.1 wt%" 及 "超出0.01 wt%" 係指限制物質之百分比含量超出百分比含量基準值。  
 Note 1: "Exceeding 0.1 wt%" and "exceeding 0.01 wt%" indicate that the percentage content of the restricted substance exceeds the reference percentage value of presence condition.  
 備考2: "○" 係指該項限制物質之百分比含量未超出百分比含量基準值。  
 Note 2: "○" indicates that the percentage content of the restricted substance does not exceed the percentage of reference value of presence.  
 備考3: "-" 係指該項限制物質為排除項目。  
 Note 3: "-" indicates that the restricted substance corresponds to the exemption.  
 OS-214plus ~ OS-314plus



# OS-Series Printers Quick Installation Guide

OS-314plus / OS-214plus / OS-2140  
 OS-2140D / OS-2140DZ / OS-2140Z

- 快速安裝指南
- 快速安装指南
- Guía Rápida
- Rapide guide
- Bedienerhandbuch
- Impressora Guia de instalação rápida
- Guida Rapida
- Mini Kılavuzu
- Pedoman Penginstalan Cara Cepat
- دليل التركيب السريع

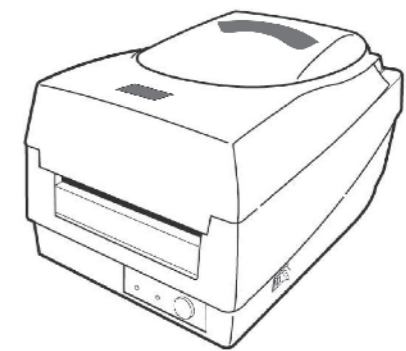

Part No: 49-21403-026  
 Revision Date: Apr. 2019

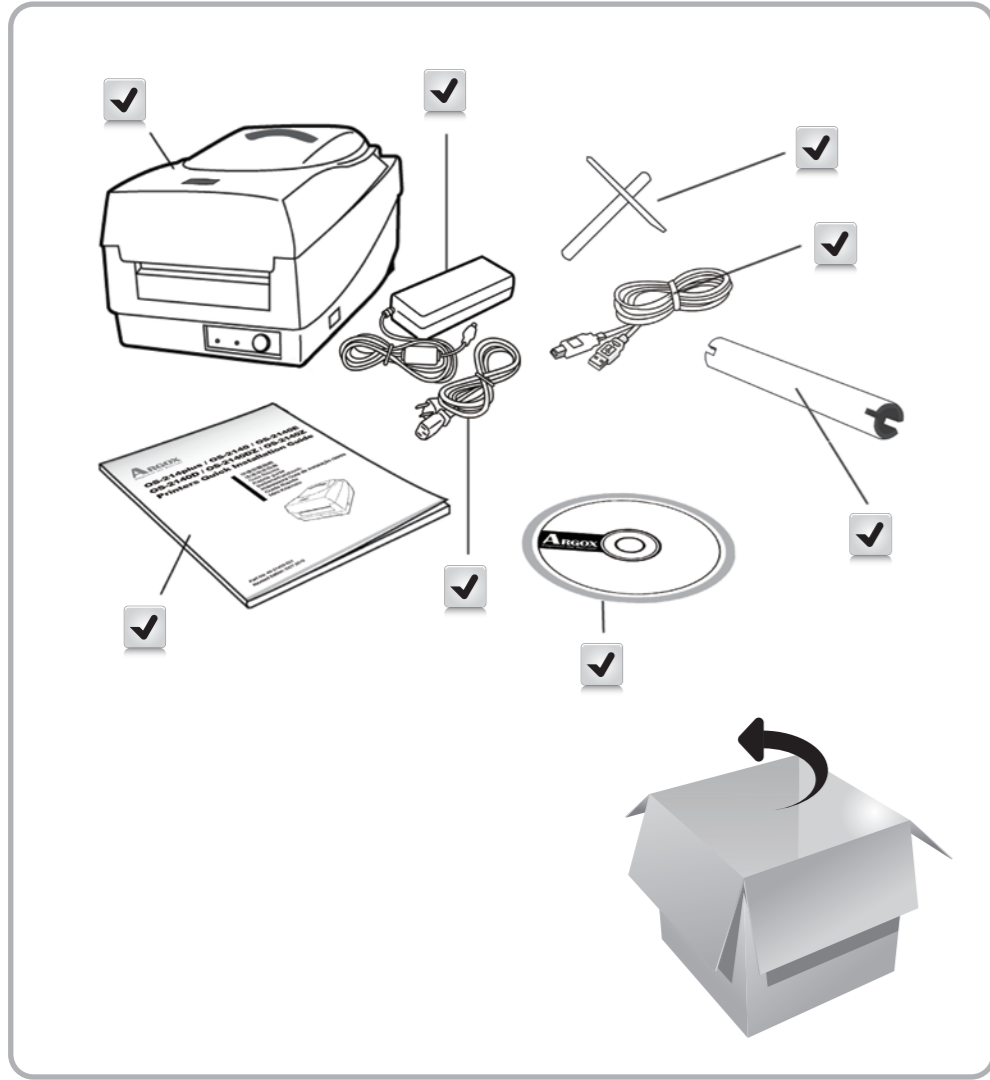

• User's Manual  
 • 使用手冊  
 • Manual del Usuario  
 • Manuel de l'utilisateur  
 • Bedienerhandbuch  
 • Manual de Utilizador  
 • Manuale Utente  
 • Kullanım Kılavuzu  
 • Panduan Pemakai  
 • دليل المستخدم

[www.argox.com](http://www.argox.com)

**A**

**C**

**B**

OS-214plus  
 OS-314plus

**D**

**English**

- A-**
- 1 Top Cover
  - 2 H Cover
  - 3 Power Indicator
  - 4 Ready Indicator
  - 5 Feed Button
  - 6 Power Switch

- B-**
- 1 Parallel Port
  - 2 USB
  - 3 RS232 Serial
  - 4 Power Jack

- C-**
- 1 Ribbon Pick-up Holder
  - 2 Media Hanger
  - 3 Release Levers

- D-**
- 1 Ribbon Supply Holder
  - 2 Platen Roller
  - 3 Thermal Print Head

**繁體中文**

- A-**
- 1 上蓋
  - 2 H型蓋
  - 3 電源燈
  - 4 確認燈
  - 5 送紙鍵
  - 6 電源開關(O=Off, I=On)

- B-**
- 1 並列埠
  - 2 USB埠
  - 3 RS232 串列埠
  - 4 電源連接器

- C-**
- 1 碳帶回收軸
  - 2 紙捲供應端
  - 3 閉鎖卡條

- D-**
- 1 碳帶供應軸
  - 2 滾軸
  - 3 印字頭模組

**简体中文**

- A-**
- 1 上盖
  - 2 H型盖
  - 3 电源灯
  - 4 确认灯
  - 5 送纸按钮
  - 6 电源开关(O=Off, I=On)

- B-**
- 1 并行端口
  - 2 USB端口
  - 3 RS232 串行端口
  - 4 电源连接器

- C-**
- 1 碳带回收轴
  - 2 纸卷供应端
  - 3 闭锁卡条

- D-**
- 1 碳带供应轴
  - 2 滚轴
  - 3 打印头模组

**Español**

- A-**
- 1 Cubierta de arriba
  - 2 Cubierta H
  - 3 Indicador de energía
  - 4 Indicador READY
  - 5 Botón FEED (Alimentación)
  - 6 Interruptor de energía (O = Off, I = A)

- B-**
- 1 Paralelo
  - 2 USB
  - 3 RS232
  - 4 Conector de alimentación

- C-**
- 1 Rodillo de suministro de cinta
  - 2 Soporte de suministro de papel
  - 3 Seguro de liberación

- D-**
- 1 Suministro de cinta
  - 2 Rodillo arrastre
  - 3 Cabezal de impresión

**Français**

- A-**
- 1 Couverture
  - 2 Couverture H
  - 3 Indicateur d'alimentation
  - 4 Prêt Indicateur
  - 5 Bouton d'alimentation
  - 6 Power (O = Off, I = On)

- B-**
- 1 Parallèle
  - 2 USB
  - 3 Serial RS232
  - 4 Connecteur d'alimentation

- C-**
- 1 rouleau de ruban d'approvisionnement
  - 2 Support l'approvisionnement en papier
  - 3 Levier de sortie

- D-**
- 1 Communication de la bande
  - 2 Roller glisser
  - 3 Tête d'impression

**Deutsch**

- A-**
- 1 Deckel
  - 2 H Schutzkappe
  - 3 POWER-LED
  - 4 Zustandsanzeige
  - 5 FEED-Taste
  - 6 Netzschalter (O = AUS, I = An)

- B-**
- 1 Paralleler Anschluß (OS-214plus)
  - 2 USB
  - 3 RS232 seriell
  - 4 Stromanschluß

- C-**
- 1 Carbonbandauf-nahmespindel
  - 2 Etikettenrollenhalter
  - 3 Knöpfe zum Entrasten der Halterung

- D-**
- 1 Carbonbandabrollspindel
  - 2 Andruckwalze
  - 3 Druckkopf-Modul

**Português**

- A-**
- 1 Tampa Superior
  - 2 Tampa H
  - 3 Indicador de Energia
  - 4 Indicador de Funcionamento
  - 5 Tecla de avanço de papel
  - 6 Interruptor Ligar/ Desligar (O= Desligar, I = Ligar)

- B-**
- 1 Paralela
  - 2 USB
  - 3 Série RS232
  - 4 Conector de Energia

- C-**
- 1 Enrolador de Filme
  - 2 Suporte do rolo de papel
  - 3 Manetes para libertar papel

- D-**
- 1 Suporte do rolo de filme
  - 2 Rolo de tracção
  - 3 Módulo da cabeça de impressora

**Italia**

- A-**
- 1 Coperchio superiore
  - 2 Frontalino
  - 3 LED Accensione
  - 4 LED Pronto
  - 5 Pulsante avanzamento
  - 6 Interruttore accensione (O = Off, I = On)

- B-**
- 1 Porta Parallela
  - 2 USB
  - 3 Seriale RS232
  - 4 Alimentazione DC

- C-**
- 1 Perno recupero nastro
  - 2 Supporto rotolo
  - 3 Leve di rilascio

- D-**
- 1 Perno nastro nuovo
  - 2 Rullo stampa
  - 3 Modulo Testina di stampa

**Türkçe**

- A-**
- 1 Üst Kapak
  - 2 Ön Slot Kapağı
  - 3 Güç LED'i
  - 4 Hazır LED'i
  - 5 İlerletme Düğmesi
  - 6 Açma/Kapatma Düğmesi

- B-**
- 1 Paralel
  - 2 USB Girişi
  - 3 Seri Port Girişi
  - 4 Adaptör Girişi

- C-**
- 1 Ribon Toplama tutamaçları
  - 2 Etiket çubuğu
  - 3 Serbest bırakma Tırnakları

- D-**
- 1 Ribon kaynağı tutamaçları
  - 2 Kauçuk Silindir
  - 3 Termal Yazıcı Kafası

**Bahasa Indonesia**

- A-**
- 1 Penutup Atas
  - 2 Penutup H
  - 3 Power Indikasi
  - 4 Ready/Siap Indikasi
  - 5 Tombol Maju
  - 6 Saklar Power

- B-**
- 1 Port Paralel
  - 2 USB
  - 3 Serial
  - 4 Colokan Power

- C-**
- 1 Penyanggah Dudukan Ribbon/Pita
  - 2 Gantungan Media
  - 3 Tuas Pelepas

- D-**
- 1 Dudukan Pemasuk Ribbon/Pita
  - 2 Platen Penggulung
  - 3 Print Head Thermal

**العربية**

- A-**
- 1- الغطاء العلوي
  - 2- غطاء H.
  - 3- مؤشر الطاقة
  - 4- مؤشر الإستعداد
  - 5- زر التقدمة
  - 6- مفتاح الطاقة

- B-**
- 1- المنفذ المتوازي
  - 2- يو اس بي
  - 3- منفذ تسلسلي RS232.
  - 4- فاس الطاقة

- C-**
- 1- حامل الشريط
  - 2- مغلي الوسائط
  - 3- محرر الأدرعة

- D-**
- 1- حامل مرود الشريط
  - 2- اسطوانة الطباعة
  - 3- رأس الطابعة الحراري

