

# **Ethernet Printer**

## **User's Guide**

Version 1.03

## Table of Contents

<b>1. ETHERNET CARD SPECIFICATIONS</b> .....	<b>4</b>
<b>2. ADDITIONAL COMMANDS</b> .....	<b>5</b>
<b>TABLE1: PARAMETER ID</b> .....	<b>8</b>
<b>TABLE 2</b> .....	<b>11</b>
<b>3. ETHERNET PRINTER STATUS/ACTIVITY INDICATORS</b> .....	<b>12</b>
3.1 Ethernet Module Status/Activity indicators .....	12
3.2 Printer Status/Activity indicators.....	12
<b>4. OBTAINING THE IP ADDRESS</b> .....	<b>13</b>
<b>5. INFORMATION AND SETTING</b> .....	<b>16</b>
<b>6. ETHERNET PORT SETTING</b> .....	<b>18</b>
<b>7. LCD ETHERNET SETTING</b> .....	<b>28</b>
<b>8. RESET ETHERNET CARD</b> .....	<b>30</b>
<b>9. REBOOT ETHERNET CARD</b> .....	<b>31</b>
<b>10. ETHERNET CARD REPLACEMENT</b> .....	<b>32</b>
10.1 A-2240E Ethernet Card Replacement.....	32
10.2 X-2300E/X-3200E Ethernet Card Replacement .....	34
10.3 CP-2140E Ethernet Card Replacement .....	36
10.4 OS-2130DE Ethernet Card Replacement .....	39
<b>11. PRINTER UTILITY</b> .....	<b>40</b>
11.1 Download/Upgrade firmware .....	40
11.2 Printer setting.....	42

<b>11.3 Printer Info .....</b>	<b>45</b>
<b>12.SELF-TEST DIAGNOSIS .....</b>	<b>47</b>
<b>12.1 Perform Self-test Diagnosis.....</b>	<b>47</b>

## 1. Ethernet Card Specifications

Items	Specifications
CPU	32-bits, ARM-922, 100MHz
RAM	8 MBytes ( 4 M * 16Bits )
ROM	4 MBytes
Ethernet	<ol style="list-style-type: none"> <li>1. Port: RJ-45 connector</li> <li>2. LAN: 10/100 Mbps ( Auto Detect )</li> <li>3. Protocol: ARP, IP, ICMP, UDP, TCP, HTTP, DHCP, rawTCP, LPR, IPP, SNMPTrap</li> <li>4. Mode: TCP Server/Client, UDP Client</li> <li>5. Setup: HTTP Browser Setup</li> <li>6. Security: Setup Password</li> </ol>
Digital I/O Port	Digital I/O * 5, USB 2.0 * 2
Watch Dog Function	
Firmware	Firmware On-line Updated Via Ethernet/USB
LED Lamp	Power
Environment	Operating Temperature: 0°C ~ 70°C, Storage Temperature: -20°C ~ 50°C
Dimensions	67.8 x 64 x 17.2 mm ( W x L x H )
Weight	32 g

## 2. Additional Commands

### Parameter types:

- None: no parameter is required
- Signed integer. e.g. +100 or -23
- Unsigned integer. e.g. 32
- Signed byte. Just one byte binary data. e.g.  
+3 is represented as 0x03(03H), and -1 as 0xff (0FFH).

Command	Description
<ESC>KIZA	<p>*Enable/disable the switch detection of the print head if it is opened.</p> <p>*Syntax: &lt;ESC&gt;KIZAm</p> <p>*Parameter:</p> <p style="padding-left: 40px;">m = 0; disable the switch detection of print head if it is opened (default)</p> <p style="padding-left: 40px;">m= 1; enable the switch detection of print head if it is opened</p> <p><i>If this function is enabled, the label auto-calibration will be performed when the print head is closed.</i></p>
<ESC>KJA	Request the printer status through Ethernet to be displayed on the web page. Information about the printer status is listed in <a href="#">TABLE1</a> .
<ESC>KJB	End Job
<ESC>KJH	Enable the printer to check if Ethernet card is alive or not every second.
<ESC>KJI	Disable the printer to check if Ethernet card is alive or not every second.
<ESC>KJJ	Start Job
<ESC>KJK	<p>*Reset the printer function.</p> <p>*Syntax: &lt;ESC&gt;KJKm</p> <p>*Parameter:</p> <p style="padding-left: 40px;">m=0 disable the reset function (default)</p> <p style="padding-left: 40px;">m=1 enable the reset function</p> <p><i>This command is for printer configuration.</i></p>
<ESC>KJL	<p>*SNMP broadcasted function setting.</p> <p>*Syntax: &lt;ESC&gt;KJLmnq</p> <p>*Parameter:</p> <p style="padding-left: 40px;">m= 0, disable the Ethernet card to enquire to reset the printer (default)</p> <p style="padding-left: 40px;">m=1, enable the Ethernet card to enquire to reset the printer.</p> <p style="padding-left: 40px;">n= 0, disable the SNMP function (default)</p> <p style="padding-left: 40px;">n=1, enable the SNMP function</p> <p style="padding-left: 40px;">q= 1~9 seconds; the time interval which SNMP enquire for the</p>

	<p>printer status. (default value:1)</p> <p><i>This command is for Ethernet card to enquire Printer.</i></p>
<ESC>KJOETHERNET	<p>*Ethernet IP addresses</p> <p>*Syntax: &lt;ESC&gt;KJOETHERNETm,m,m,m,n,n,n,n,o,o,o,q,q,q,q,q</p> <p>*Parameter: “m,m,m,m,”: IP address  “n,n,n,n,”: subnet mask  “o,o,o,o,”: gateway  “q,q,q,q,”: MAC address  Parameters must be HEX values.</p> <p>*Example:  IP address:192,168,0,42  (“m,m,m,m,”=“0xC0 0x2C 0xA8 0x2C 0x00 0x2C 0x2A”)</p> <p><i>After configuring the Ethernet related settings or upgrading firmware, the Ethernet card will send this command to the printer. Use the printer self test to get the Ethernet related information.</i></p>
<ESC>KJPETHERNET	<p>* IP addresses setting.</p> <p>*Syntax: &lt;ESC&gt;KJPETHERNETa,a,a,a,b,b,b,b,</p> <p>*Parameter: “a,a,a,a,”: IP address  “b,b,b,b,”: subnet mask  Parameters must be HEX values.</p> <p>*Example:  IP address:192,168,0,42  (“a,a,a,a,”=“0xC0,0xA8,0x00,0x2A”)</p> <p>If “a,a,a,a,”=“0x00 0x2C 0x00 0x2C 0x00 0x2C 0x00 0x2C”, the setting will become DHCP (auto IP address).</p> <p><i>You can send this command to Ethernet card through PC; use the printer self test to get the Ethernet related information.</i></p> <p><i>This command is for configuring the Ethernet card.</i></p>
<ESC>KJQETHERNET	<p>*Ethernet card gateway setting.</p> <p>*Syntax: &lt;ESC&gt;KJQETHERNETc,c,c,c,</p> <p>*Parameter: “c,c,c,c,”: Ethernet card gateway  Parameters must be HEX values.</p> <p>*Example:  Gateway:255,255,248,0  (“c,c,c,c,”=“0xFF 0x2C 0xFF 0x2C 0xF8 0x2C 0x00”)</p> <p><i>You can send this command to Ethernet card through PC; use the printer self test to get the Ethernet related information.</i></p>

	<i>This command is for configuring the Ethernet card.</i>
<ESC>KJR	<p>* Ethernet card version.</p> <p>*Syntax: &lt;ESC&gt;KJRm,nn</p> <p>*Example: &lt;ESC&gt;KJR5,21; Ethernet card version is 5,21.</p> <p><i>After upgrading the firmware, the Ethernet card will send this command to the printer. Use the printer self test to get the Ethernet card version.</i></p>
<ESC>KJS	Start Page
<ESC>KJT	End Page
<ESC>KJU	<p>*Ethernet SNMP function</p> <p>*Syntax: &lt;ESC&gt;KJUmn</p> <p>m=0, disable the Ethernet SNMP function (default)</p> <p>m=1, enable the Ethernet SNMP function</p> <p>n= 1~9 seconds; the time interval which the SNMP enquire for the printer status. (default value:1)</p> <p>If n=0x0D, this indicates n=1 second. In other words, if n is not defined, n=1 second.</p> <p><i>This command is for printer configuration.</i></p>
<ESC>KJV	Printer aging test
<ESC>KJW	<p>*Enquire emulation function</p> <p>*Syntax: &lt;ESC&gt;KJWmnop</p> <p>m= total emulation items; m=3~9(0x33~0x39)</p> <p><i>Maybe the printer will have more emulation in the future.</i></p> <p>n= PPLA emulation; n=0(0x30), PPLA emulation does not exist. n=1(0x31), PPLA emulation is used.</p> <p>o= PPLB emulation; o=0(0x30), PPLB emulation does not exist. o=1(0x31), PPLB emulation is used.</p> <p>p= PPLZ emulation; p=0(0x30), PPLZ emulation does not exist. p=1(0x31), PPLZ emulation is used.</p> <p><i>If the user sends &lt;esc&gt;KJW to enquire emulation through Ethernet card, the printer returns &lt;esc&gt;KJW3011; This represents that the printer supports 3 emulations but only PPLB and PPLZ are used in the printer now.</i></p>
<ESC>KJX	<p>Allow the printer LEDs to blink after one of the following conditions:</p> <ol style="list-style-type: none"> <li>1. Ethernet card upgrading process is complete.</li> <li>2. IP address, subnet mask and gateway configuration settings are complete.</li> </ol>
<ESC>KJYA	<p>* IP Address setting (Data transfer from the printer to the Ethernet card )</p> <p>*Syntax: &lt;ESC&gt;KJYAA,a,a,a,b,b,b,c,c,c,c</p> <p>*Parameter: "a,a,a,a,": IP address</p>

	<p>“b,b,b,b,”: subnet mask                  “c,c,c,c”: Ethernet card gateway                  Parameters must be HEX values.</p> <p>*Example:                  IP address:192,168,0,42                  (“a,a,a,a,”=”0xC0 0x2C 0xA8 0x2C 0x00 0x2C 0x2A 0x2C” )</p> <p>If “a,a,a,a,”=”0x00 0x2C 0x00 0x2C 0x00 0x2C 0x00 0x2C”, the setting will become DHCP (auto IP address).</p>																																		
<p>&lt;ESC&gt;KJYB</p>	<p>* IP Address setting                  (Communication between PC and printer )                  &lt;ESC&gt;KJYBm,a,a,a,a[,b,b,b,b,c,c,c,c]</p> <p>*Parameter: Parameter m is the setting mode; all parameters of the address must be in HEX format.</p> <table border="1" data-bbox="539 786 1449 1189"> <thead> <tr> <th>Parameter</th> <th>m</th> <th>a,a,a,a</th> <th>b,b,b,b</th> <th>c,c,c,c</th> </tr> </thead> <tbody> <tr> <td rowspan="7">Mode</td> <td>0x31</td> <td>Gateway</td> <td>Ignored</td> <td>Ignored</td> </tr> <tr> <td>0x32</td> <td>Subnet Mask</td> <td>Ignored</td> <td>Ignored</td> </tr> <tr> <td>0x33</td> <td>Subnet Mask</td> <td>Gateway</td> <td>Ignored</td> </tr> <tr> <td>0x34</td> <td>IP Address</td> <td>Ignored</td> <td>Ignored</td> </tr> <tr> <td>0x35</td> <td>IP Address</td> <td>Gateway</td> <td>Ignored</td> </tr> <tr> <td>0x36</td> <td>IP Address</td> <td>Subnet Mask</td> <td>Ignored</td> </tr> <tr> <td>0x37</td> <td>IP Address</td> <td>Subnet Mask</td> <td>Gateway</td> </tr> </tbody> </table>	Parameter	m	a,a,a,a	b,b,b,b	c,c,c,c	Mode	0x31	Gateway	Ignored	Ignored	0x32	Subnet Mask	Ignored	Ignored	0x33	Subnet Mask	Gateway	Ignored	0x34	IP Address	Ignored	Ignored	0x35	IP Address	Gateway	Ignored	0x36	IP Address	Subnet Mask	Ignored	0x37	IP Address	Subnet Mask	Gateway
Parameter	m	a,a,a,a	b,b,b,b	c,c,c,c																															
Mode	0x31	Gateway	Ignored	Ignored																															
	0x32	Subnet Mask	Ignored	Ignored																															
	0x33	Subnet Mask	Gateway	Ignored																															
	0x34	IP Address	Ignored	Ignored																															
	0x35	IP Address	Gateway	Ignored																															
	0x36	IP Address	Subnet Mask	Ignored																															
	0x37	IP Address	Subnet Mask	Gateway																															

**TABLE1: PARAMETER ID**

Parameter	ID ( 4 bytes)	Length (bytes)	Settings	
All Parameters	0	0		
Firmware Version	2	24	( Up to 24 characters )	
Printer Resolution	5	4	0: 203 1: 300 2: 600 3: 900	4:100
Standard RAM Size	7	4	4GB	
Available RAM Size	8	4	4GB	
Standard Flash Memory Size	9	4	0: 2MB 1: 1MB 2: 4MB	A: 1GB B: 2GB C: 4GB



			3. 8MB 4. 16MB 5. 32MB 6. 64MB 7. 128MB 8. 256MB 9. 512MB	D: 8GB E: 16GB
Available Flash Memory Size	10	4	4GB	
DT/ TT	11	4	0: DT mode 1: TT mode	
Media Sensor Type	12	4	0: Reflective 1: See Through1 2: See Through2	
Print Mode	14	4	00000000: Normal 10000000: Backfeed Enable 20000000: Cutter Enable 30000000:Peeler Enable	
Cut Offset	16	4		
Peel Offset	17	4		
Vertical Offset	18	4		
Horizontal Offset	19	4		
TPH Offset	20	4		
Print Width	21	4	10 ~ 108 (mm)	
Print Length	22	4	100 (inches)	
Darkness	23	4	1 ~ 15 (0~30)	
Speed	24	4	1 ~ 12	
Inter Font Symbol Set	27	4	ab00 total: 4bytes a: 1=7 bit b: 1~19 0=8 bit (see <a href="#">table2</a> and show symbol set)	
Total Printed Label NO.	28	4	(Only F20L have)	
Total Printed Label Length	29	4		
Labels CAL. Result	31	4	abcd : total 4 bytes ab: reflective empty value cd: see through empty value	

Label Size	32	4	
Origin Coordination Shift	33	4	
External Card	34	4	RTC card :0x3000000 Chinese font:0x2010000 Taiwan font :0x2020000 Korean font :0x2040000 Japanese font 0x2080000
Flash Module	36	4	0:External 1:Internal 2: Internal
Serial COMM.	40	8	abcd 0000 total: 8 bytes a (Baud Rate) b (Parity) c (Data Bit) d (Stop Bit)  a: 0: 9600 1: 2400 2: 4800 3: 19200 4: 38400 5: 1200 6: 115200 7: 57600 8: 600  b: 0: NONE 1: EVEN 2: ODD c: 0: 8 BITS 1: 7 BITS  d: 0: 1 BIT 1: 2 BITS

**TABLE 2**

8 bit data (a=0)	Symbol Set (Code page)	7 bit data (a=1)	Symbol set
b=0	English (437)	b=0	USASCII
b=1	Latin 1 (850)	b=1	British
b=2	Slavic (852)	b=2	German
b=3	Portugal (860)	b=3	French
b=4	Canadian/French (863)	b=4	Danish
b=5	Nordic (865)	b=5	Italian
b=6	Turkish (857)	b=6	Spanish
b=7	Icelandic (861)	b=7	Swedish
b=8	Hebrew (862)	b=8	Swiss
b=9	Cyrillic (855)		
b=10	Cyrillic CIS 1(866)		
b=11	Greek (737)		
b=12	Greek 1 (851)		
b=13	Greek 2 (869)		
b=14	Latin 1 (1252)		
b=15	Latin 2 (1250)		
b=16	Cyrillic (1251)		
b=17	Greek (1253)		
b=18	Turkish (1254)		
b=19	Hebrew (1255)		

### 3. Ethernet Printer Status/Activity indicators

#### 3.1 Ethernet Module Status/Activity indicators

LED Status	Description	
Off (both LEDs)	No Ethernet link is detected.	
Green	Speed LED	On: 100 Mbps link Off: 10 Mbps link
Amber	Link/Activity LED	On: link up Off: link down Flashing: active

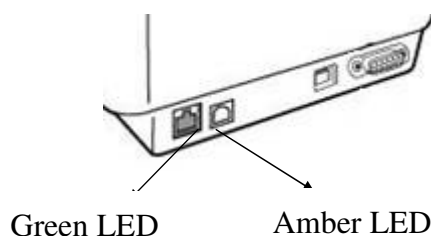

#### 3.2 Printer Status/Activity indicators

LED Status	Blinking LED	Description
Wait for Ready	READY	The printer waits for printer to get ready. It will take approximately 20 seconds.

## 4. Obtaining the IP Address

Printer can obtain the IP addresses from the following modes:

### A. Using router or similar device to assign the IP address to the printer

1. Connect both PC and printer using the internet cable to the Router LAN port.
2. Get the related information from the PC **Internet Protocol (TCP/IP) Properties**.  
(Note: If the PC is assigned with a static IP address, please keep a record of the current static IP related information, in case that you may need the information to restore its original setting)

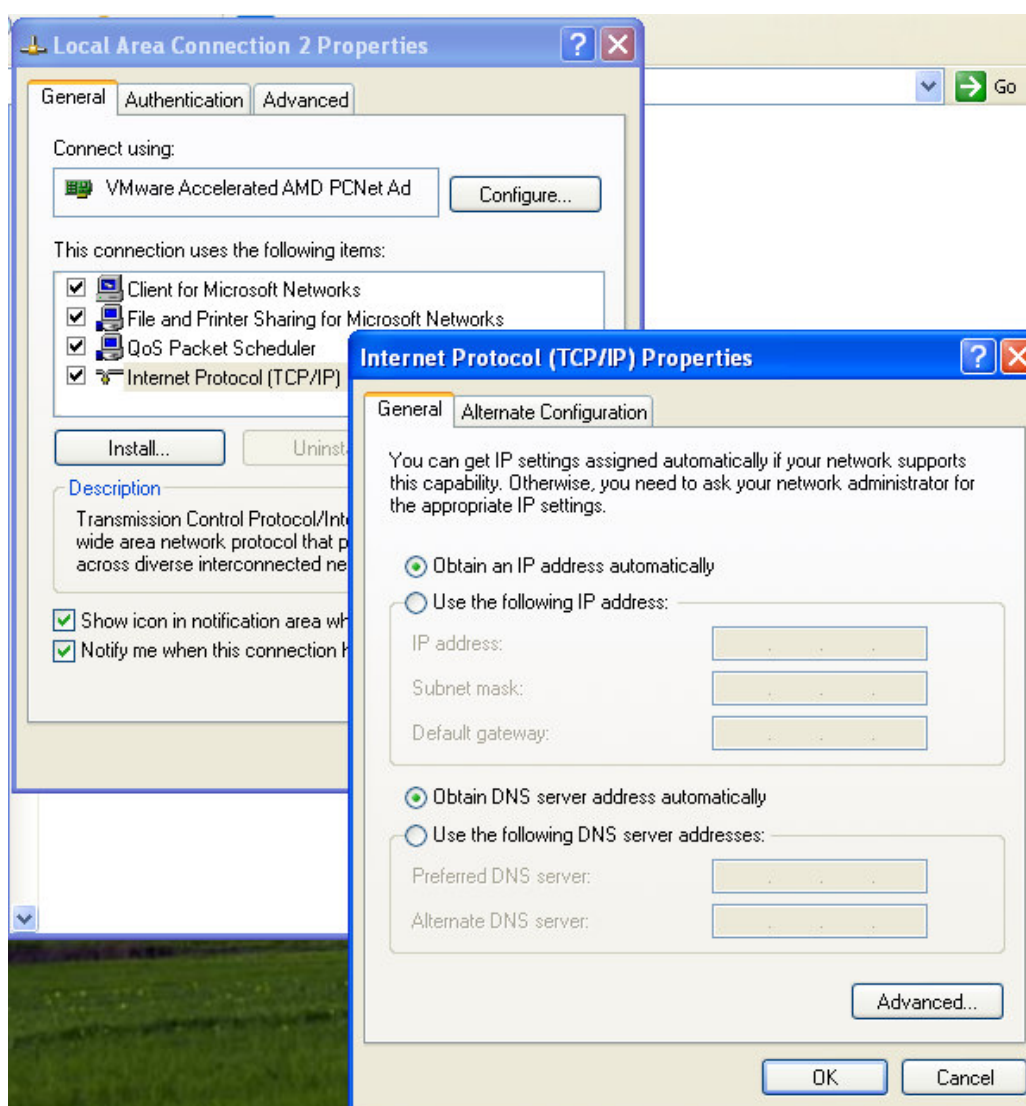

- Search the IP address of the Router assigned to the printer. The following is an example of using the 3COM WL-602 Router. Launch the web browser and enter the default IP address to open the Router homepage (For example: The default IP address of the 3COM WL-602 Router is <http://192.168.1.1>)



When the printer is turned on, READY LED will blink. Wait for about 20 seconds for the system to get ready.

- Enter the user name and password (the default settings are "Admin").
- Click **Log in** to enter the main menu. Then click **LAN setting** to enter the system status menu.
- Click **DHCP Clients List** to view the printer IP addresses which are assigned to the PC.

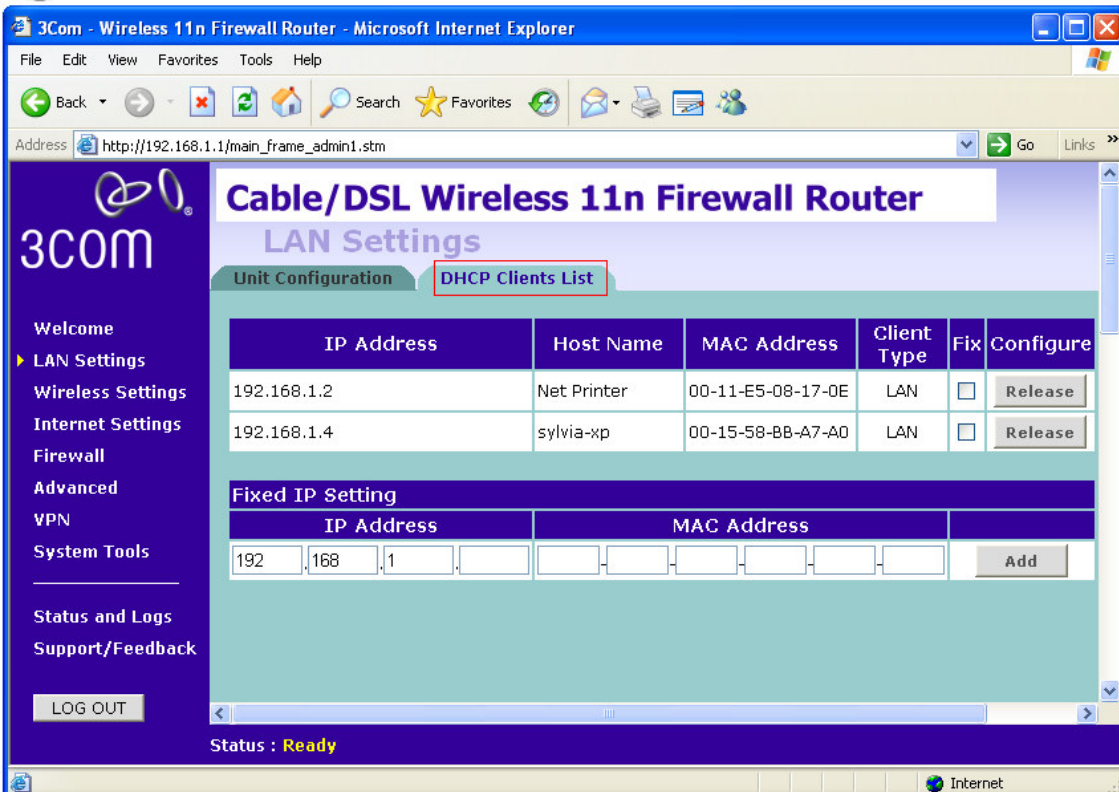

➤ *Note: When the printer obtains the assigned IP address, it is recommended to retain that IP*

*address; otherwise this will delay the time for the printer to get ready.*

## B. Using the Ethernet card static IP address

Connect the printer and the PC using the cable. Turn on the printer and wait for about 1 minute. The printer will automatically get the default IP addresses (192.168.1.100). The default IP address can be modified, make sure that it connects correctly: the first 3 sections of the PC IP address should be the same with the printer IP address (ex. 192.168.1.xxx). The subnet mask should be 255.255.255.0.

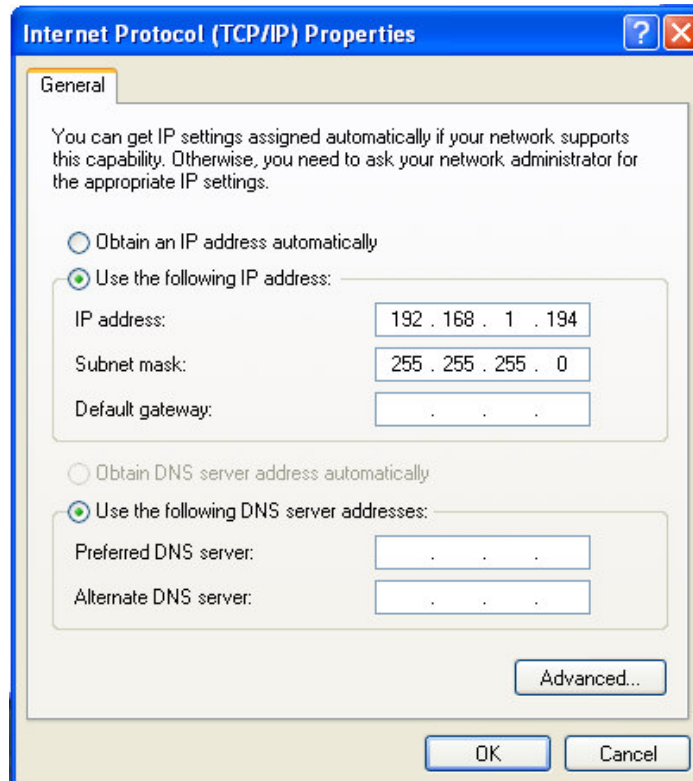

## C. Send additional commands to set the IP address through other communication interface (USB, RS-232 etc.)

<ESC>KJPETHERNET

<ESC>KJQETHERNET

## 5. Information and Setting

1. Launch a browser and enter the printer IP address. You can view the Ethernet card (**SERVER STATUS**) and printer (**PRINTER STATUS**) related status information.

The screenshot shows a web browser window with the address bar displaying `http://192.168.100.102/`. The page has a navigation bar with three tabs: **SERVER STATUS** (selected), **PRINTER STATUS**, and **CONFIG**. The main content area is titled **SERVER STATUS** and contains the following information:

**Server Status** [\[ Print \]](#)

**Machine Information**

- Firmware Version: 0.62
- MAC Address: 00-11-E5-01-13-20

**Server Information**

- Server Name: Net Printer
- Description: KCodes 802 USB Device Server

**TCP/IP Status**

- IP Address : 192.168.100.102 (dhcp)
- Subnet Mask : 255.255.255.0
- Gateway : 192.168.100.1
- DNS Server : 1.0.0.0
- DHCP Server : 192.168.100.1
- Lease Time : 259200 second

Raw TCP/JetDirect Printing: enabled  
TCP Port: 9100

The screenshot shows the same web browser window, but the **PRINTER STATUS** tab is selected. The main content area is titled **PRINTER STATUS** and contains the following information:

**Printer Status** [\[ Print \]](#)

**Printer Status**

- Firmware Version: OS-2140E PPLB 031609
- Baud Rate: 9600
- Parity Bit: NONE
- Data Bits: 8 Bits
- Stop Bit: 1 Bit
- Host Handshake: XON/XOFF & CTS/RTS
- Standard RAM Size: 8 MB
- Available RAM Size: 6016576 Bytes
- Internal Font Symbol Set: Code Page 437
- Thermal Type: DIRECT THERMAL
- Sensor Type: REFLECTIVE
- Total Printed Label No.: 0
- Total Printed Label Len.: 5159 M



2. In the **CONFIG's TCP/IP** submenu, you can configure how the Ethernet card assigns the IP address to the PC and other related settings.

The screenshot shows the CONFIG web interface. At the top, there are tabs for 'SERVER STATUS', 'PRINTER STATUS', and 'CONFIG', with 'CONFIG' selected. The language is set to 'English'. The left sidebar has a menu with 'CONFIG' selected. The main content area is titled 'Set TCP/IP Configuration'. Under the 'TCP/IP' section, there are three radio buttons: 'Automatically get IP by DHCP' (selected), 'Manual DNS' (unchecked), and 'Static IP' (checked). Below 'Static IP', there are input fields for 'IP Address' (192.168.1.100), 'Subnet Mask' (255.255.255.0), 'Default Gateway', and 'DNS Server'. There is also a checked checkbox for 'Enable Raw TCP/JetDirect Printing' and a 'TCP Port' field (9100). At the bottom, there are 'Submit' and 'Reset' buttons.

3. In the **Maintenance** submenu, you can update the firmware of the Ethernet card/printer.

The screenshot shows the CONFIG web interface. At the top, there are tabs for 'SERVER STATUS', 'PRINTER STATUS', and 'CONFIG', with 'CONFIG' selected. The language is set to 'English'. The left sidebar has a menu with 'CONFIG' selected. The main content area is titled 'Maintenance'. There are two sub-sections: 'Server' and 'Printer'. Each sub-section has two links: 'Factory Default' and 'Upgrade Firmware'.

- The accumulative time will be reset if the printer shuts down. You can get this information from the default webpage (<http://192.168.1.100/systeminfo/htm>) or other webpage.
- When updating the firmware of the Ethernet card/printer, all status monitors including Bartender status must be closed.
- After updating the Ethernet module firmware or changing of the IP address is complete, restart the printer and wait for about 1 minute; you will get the latest Ethernet module firmware version or IP address by the printer self test pages.

## 6. Ethernet Port Setting

1. Run the **Seagull Driver** file.
2. The **Windows Printer Drivers\License Agreement** window appears on the screen. Read the license agreement and select "I accept the terms in the license agreement", then click **Next**.

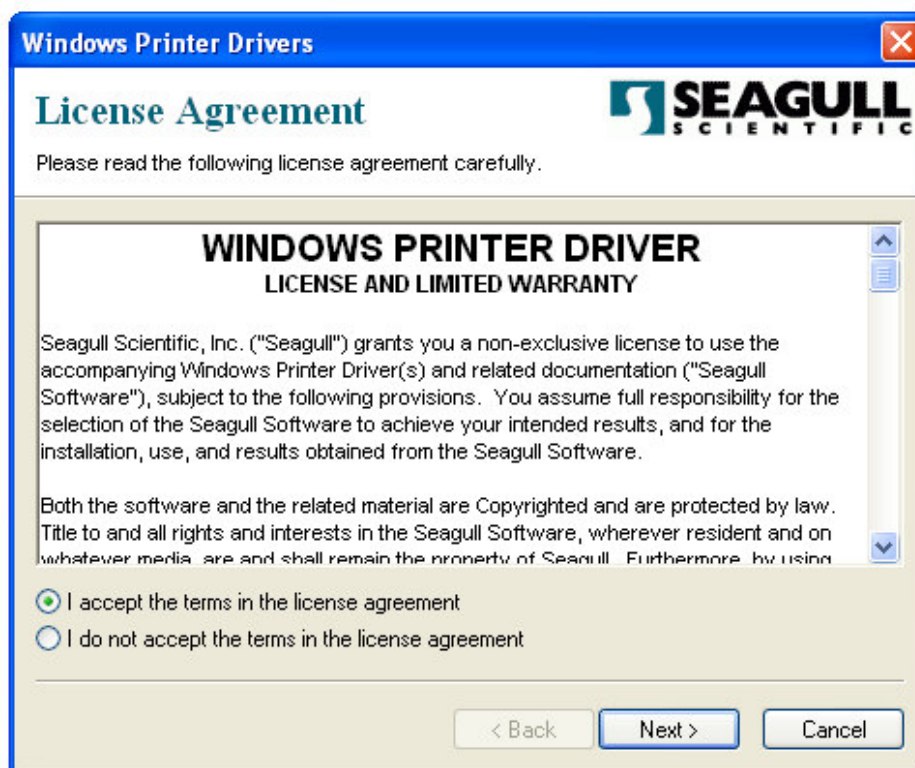

3. Click **Browse** to select the **Installation Directory** path, and then click **Next**.

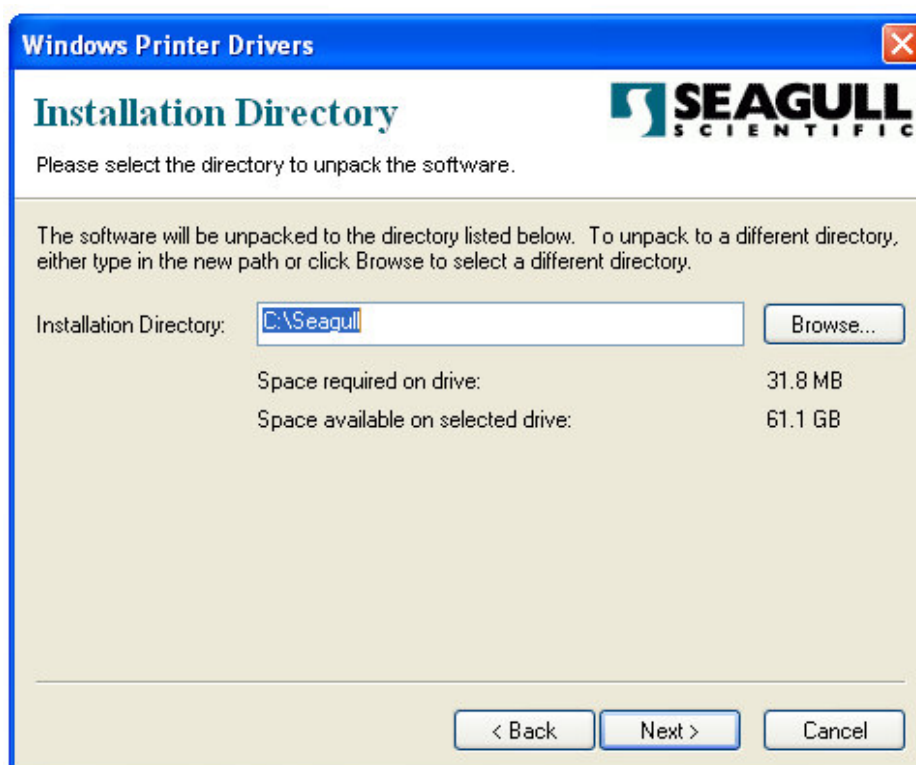

4. Select the appropriate options, and then click **Finish** to start the software installation.

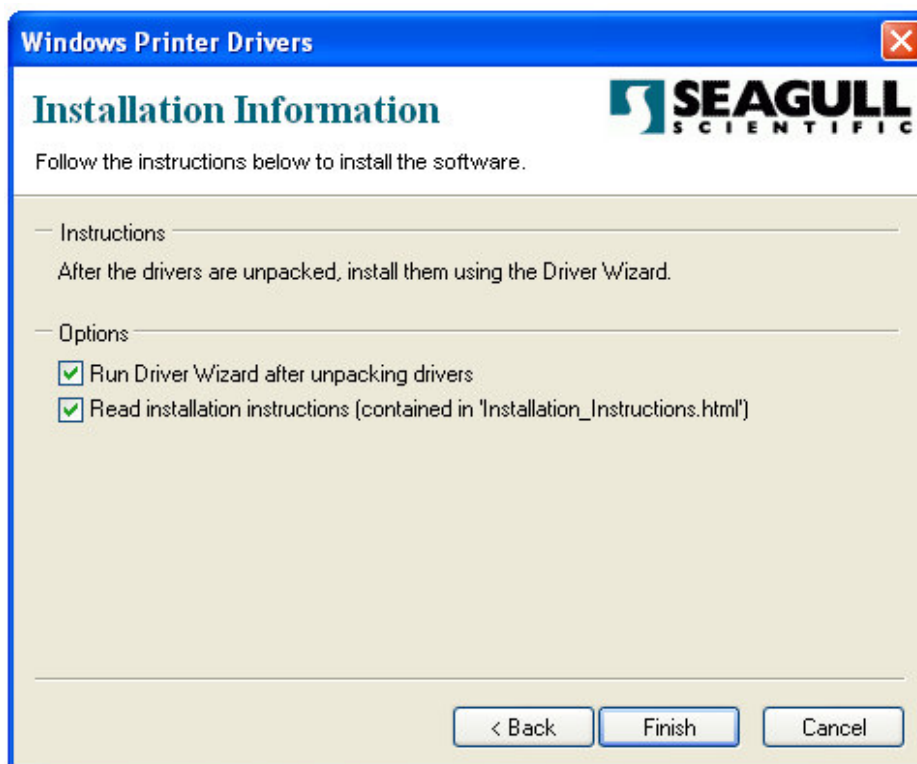

5. Windows Printer Driver installation starts.

6. A **Welcome to the Seagull Driver Wizard** window appears on the screen. Select **Install Printer Drivers**, and click **Next**.



7. Select **Install a driver for another printer**, then click **Next**.

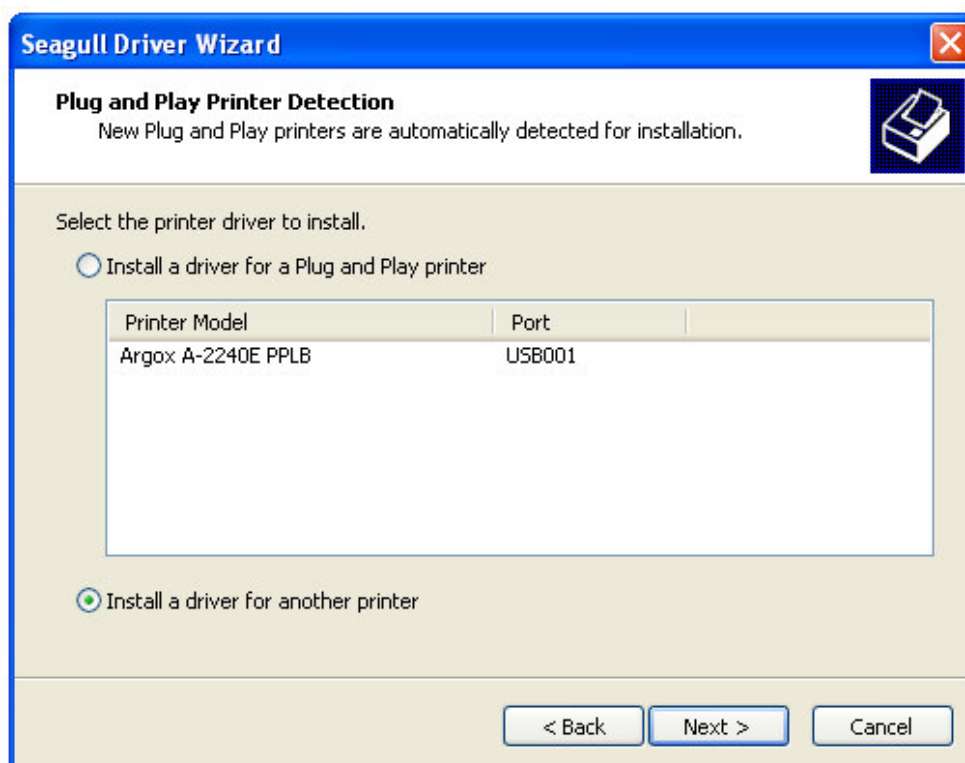

8. Select the model of your printer, and then click **Next**.

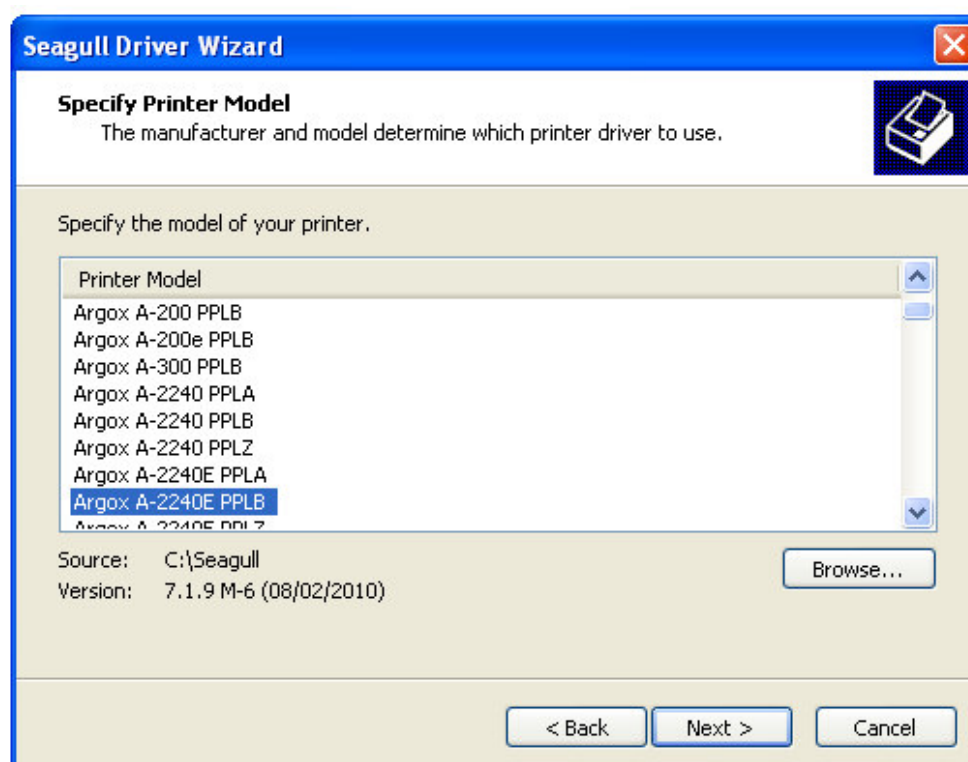

9. Click the **Create Port** button.

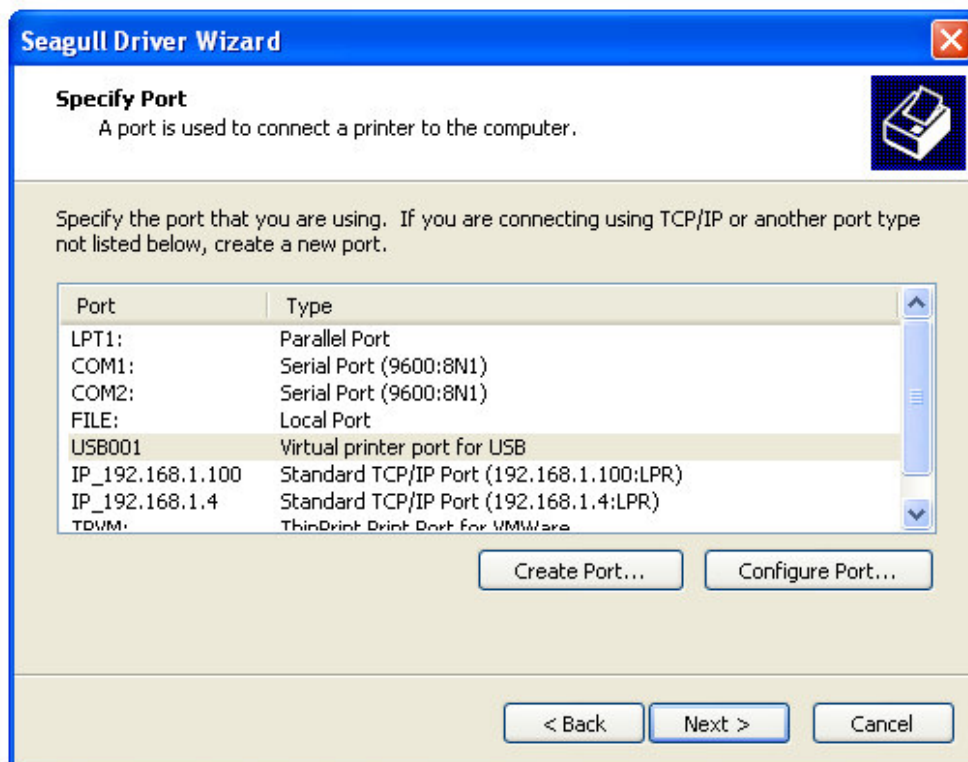

10. Select **Standard TCP/IP Port**, and click the **New Port** button.

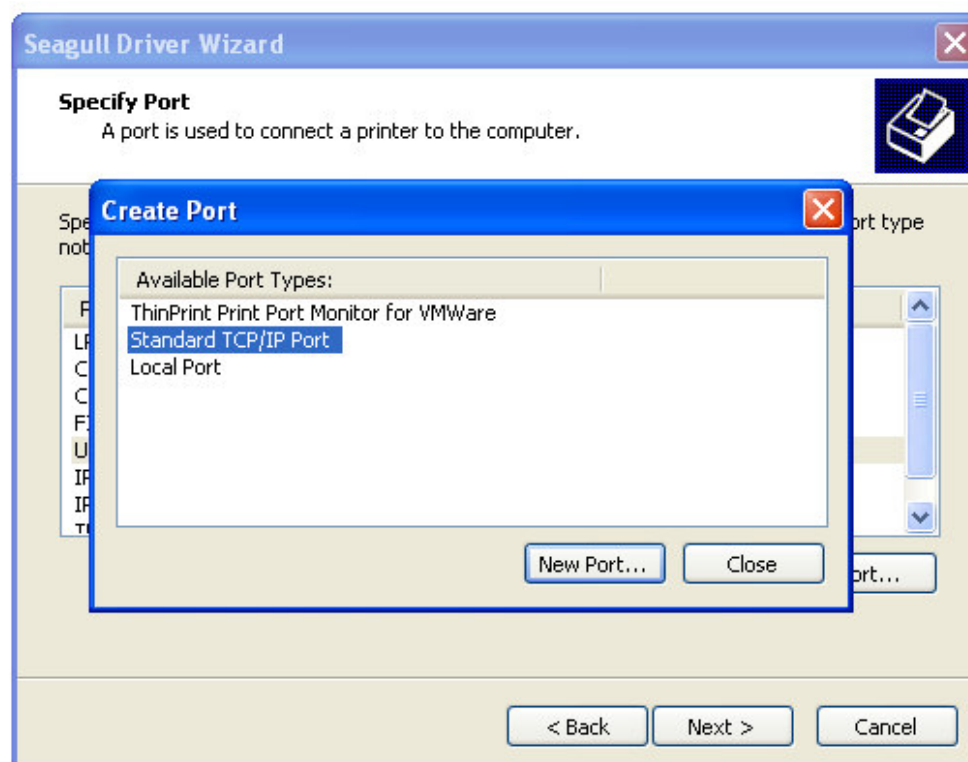

11. A **Welcome to the Add Standard TCP/IP Printer Port Wizard** window appears on the screen, click **Next**.

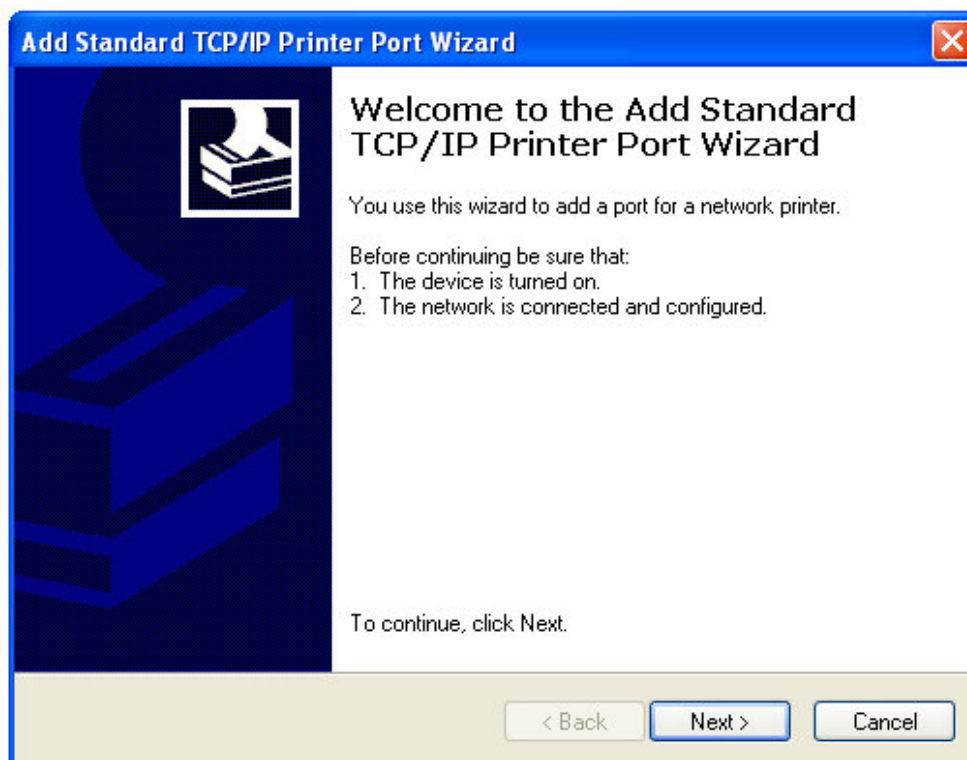

12. Enter the **IP address**, and then click **Next**.

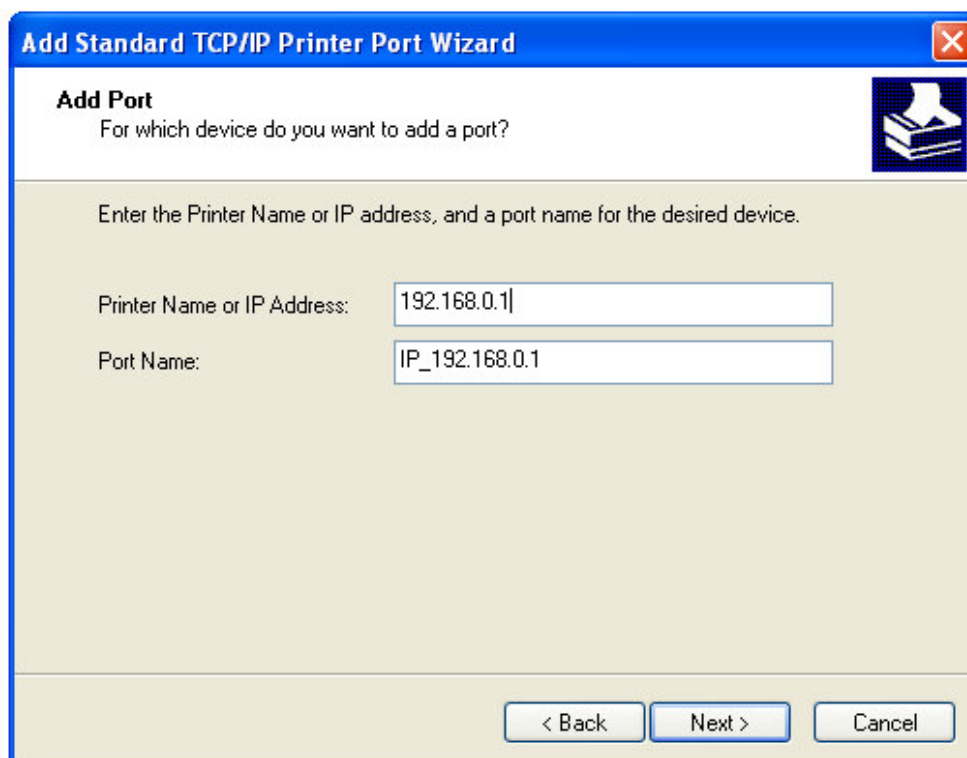

13. Select **Standard**, and then click **Next**.

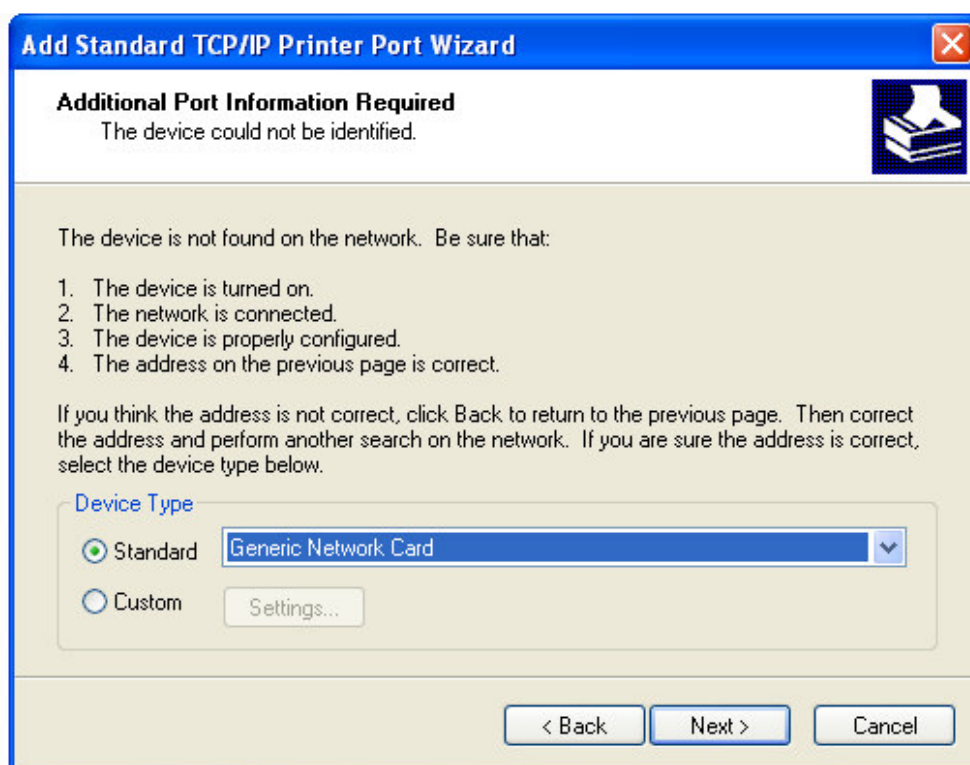

14. Click **Finish** to complete the current wizard installation.

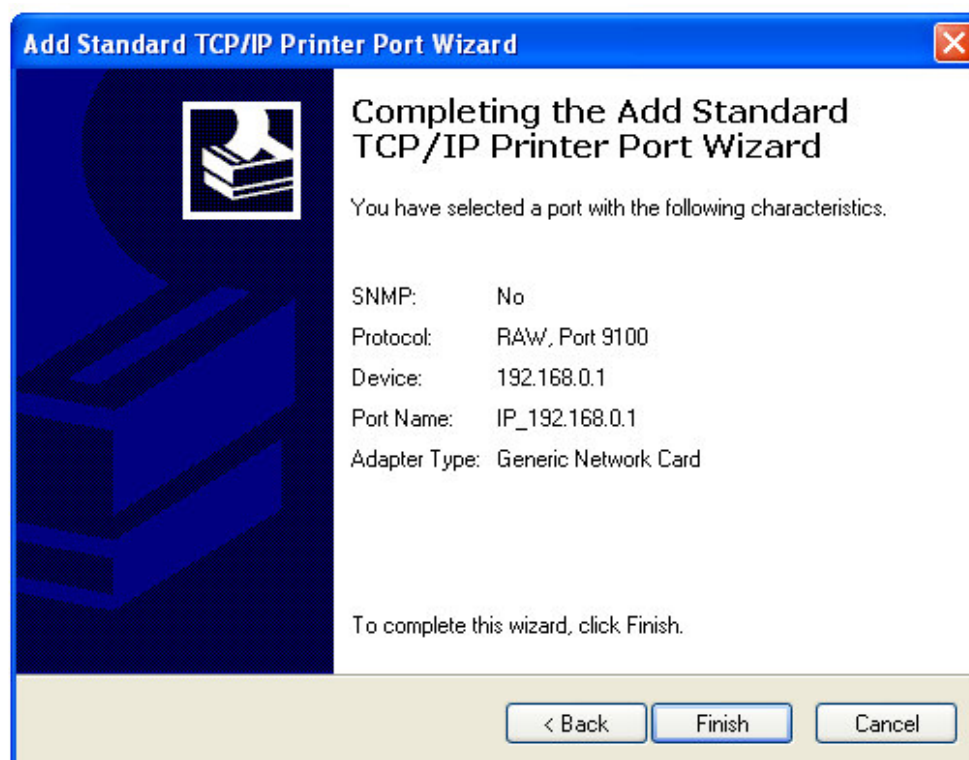

15. Return to **Specify Port** window, and click **Next**.

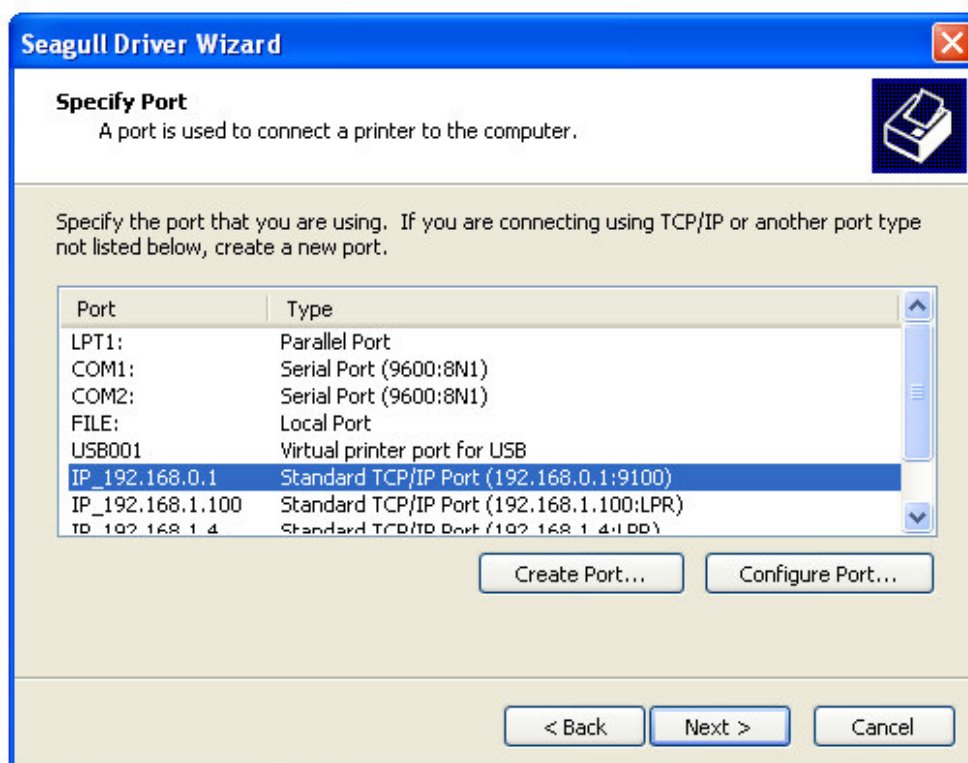

16. Specify the printer name, and then click **Next**.

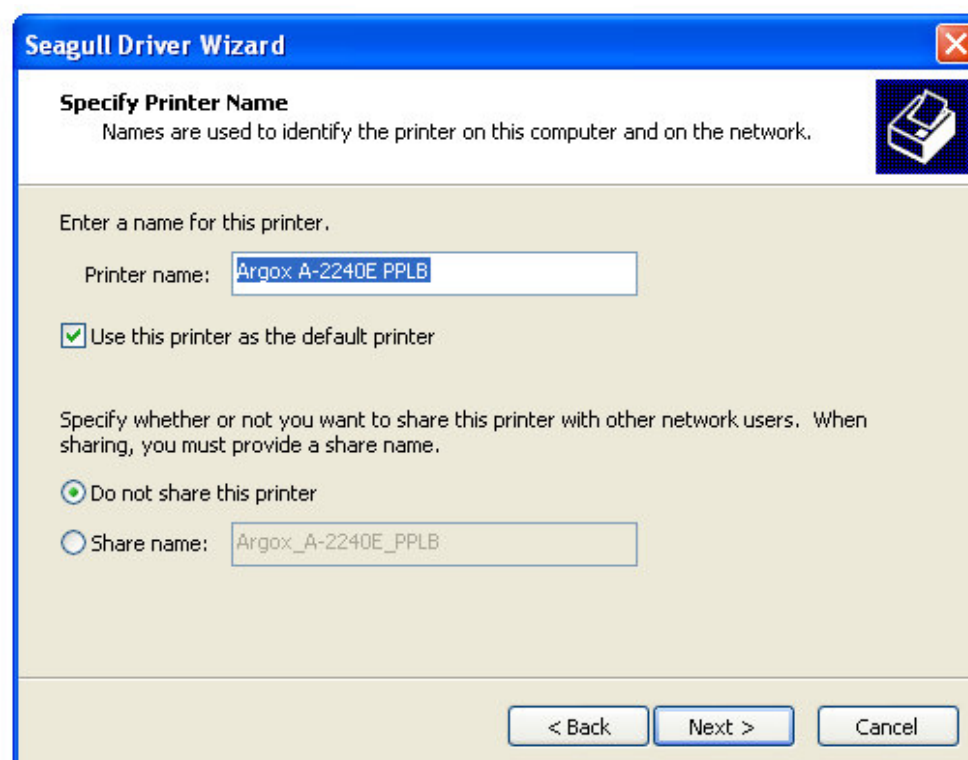



17. Click **Finish** to complete the driver installation.

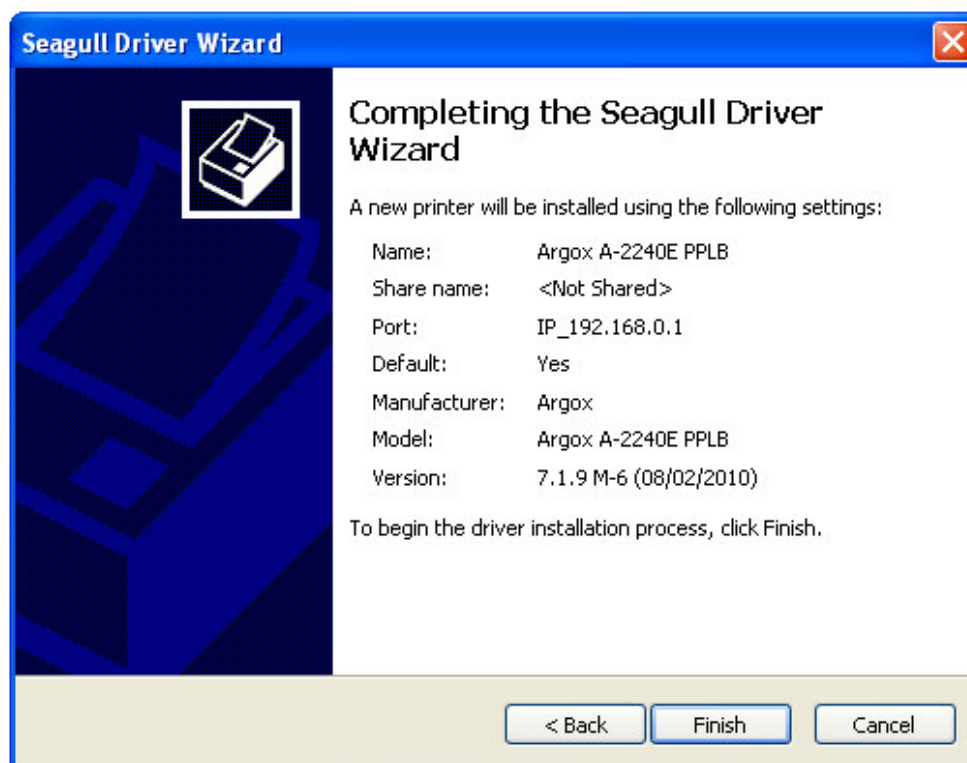

18. A **Seagull Driver Wizard Completed Successfully** window appears on the screen. Click **Close**.

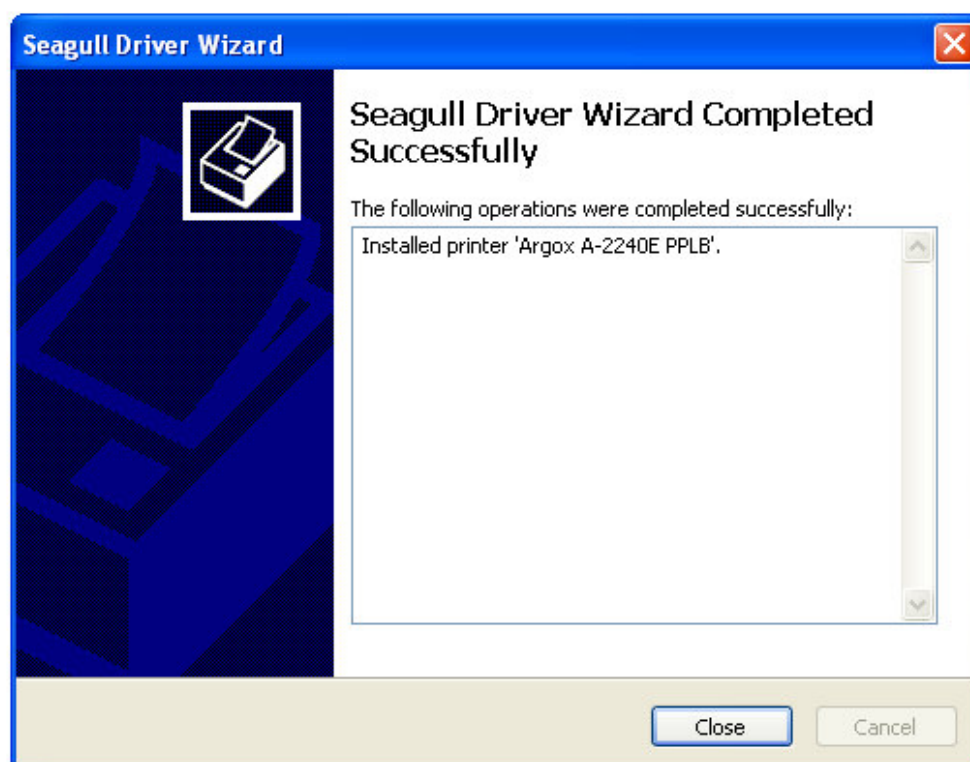

19. Choose **Raw(R)** or **LPR(L)** in the **Protocol** option, and then click **OK**.

19.1 **Raw(R)** settings as below:

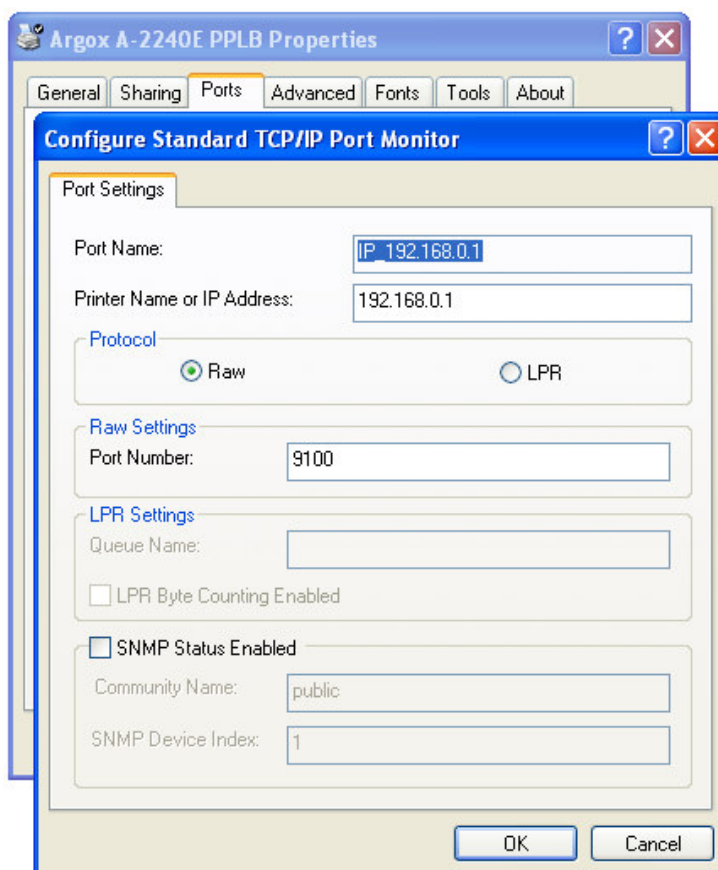

19.2 **LPR(L)** settings as below:

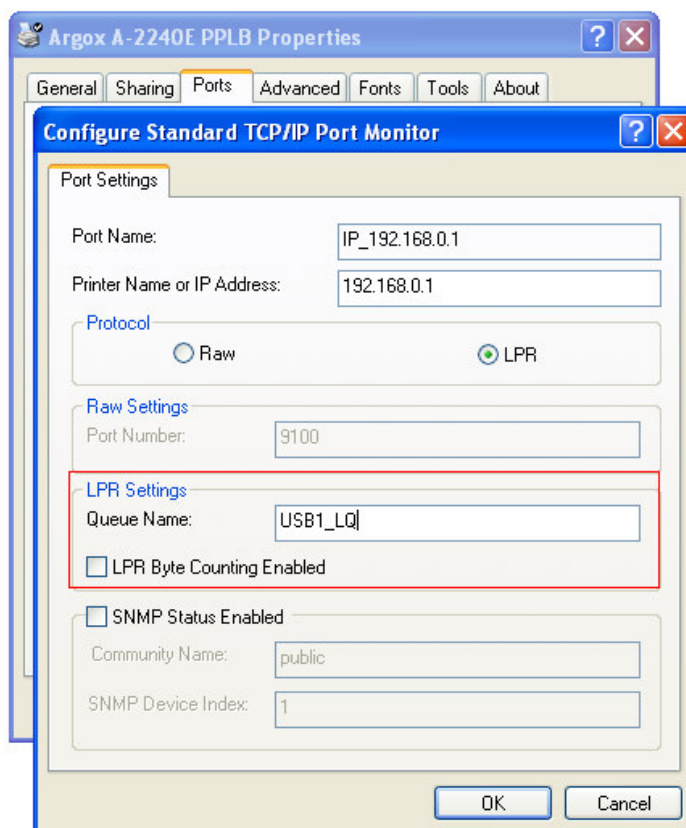

- Because **LPR(L)** does not support the bidirectional function, you must disable “Enable bidirectional support” option.

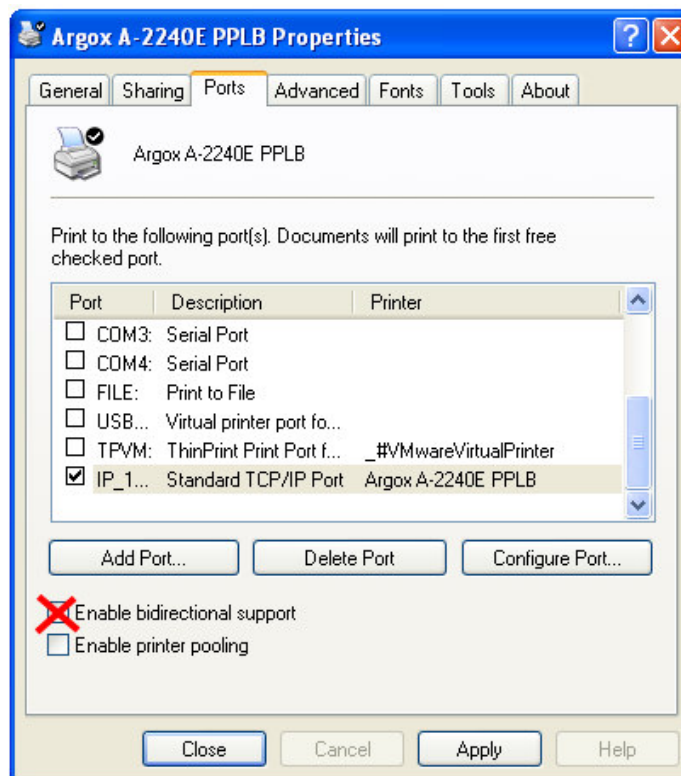

20. LPD/LPR setting is complete.



## 7. LCD Ethernet Setting

	LCD Function Display	Function Options	Description
1	DHCP	DISABLE	<p>If printer is not connected to a router, with DHCP disabled, settings of IP ADDRESS, SUBNET MASK, and DEFAULT GATEWAY settings will be available on LCD.</p> <p>If DISABLE is changed to be ENABLE, LCD will prompt "ETHERNET CARD UPDATE FINISH..."</p> <p>Then please reboot the printer.</p>
		ENABLE	<p>If printer has been connected to a router, IP address will be assigned automatically by DHCP server after power on.</p> <p>If ENABLE is changed to be DISABLE, and then again set back as ENABLE, LCD will prompt "ETHERNET CARD UPDATE FINISH..."</p> <p>Then please reboot the printer.</p>
2	IP ADDRESS	xxx.xxx.xxx.xxx	<p>xxx range:0~255</p> <p>When DHCP is disabled, default IP address is 192.168.1.100.</p> <p>If “_” sign appears, it means that the DHCP setting is disabled. If not, DHCP setting is enabled.</p> <ol style="list-style-type: none"> <li>1. FEED/CONFIG. : change contents. (i.e. from 000.000.000.000 to 255.255.255.255)</li> <li>2. PAUSE/CALIBR. : shift “_”sign position. (i.e. from <u>2</u>55.255.255.255 to 255.255.255.<u>2</u>55)</li> <li>3. CANCEL/RESET.: view next function option. (“_” sign must be on the third word, for example, xx<u>x</u>).</li> <li>4. To change IP ADDRESS or</li> </ol>
3	SUBNET MASK	xxx.xxx.xxx.xxx	
4	DEFAULT GATEWAY	xxx.xxx.xxx.xxx	

			<p>SUBNET MASK, enter DEFAULT GATEWAY setting, press CANCEL button once; LCD will prompt "ETHERNET CARD UPDATE FINISH..."</p> <p>5. Restart the printer.</p> <p><i>Note: All settings are valid, if IP ADDRESS, SUBNET MASK and DEFAULT GATEWAY settings are complete and printer is restarted.</i></p>
5	MAC ADDRESS	yyyy-yyyy-yyyy	yyyy range:0000~FFFF

## 8. Reset Ethernet Card

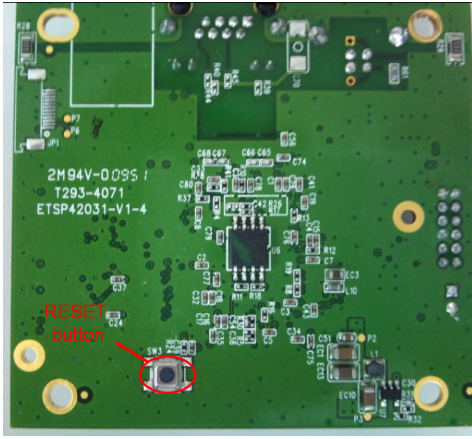
When IP address setting is complete, the user must restart the printer to check the IP address on the webpage. If the printer cannot get the correct IP address, please reset or [reboot](#) the Ethernet Card.

<b>Model</b>  <b>Reset Procedure</b>	OS-2130DE	X-2300E X-3200E	A-2240E CP-2140E
	<ol style="list-style-type: none"> <li>1. Remove all the printer covers.</li> <li>2. Turn on the printer, and then press the Ethernet card <b>RESET</b> button for 2 seconds.</li> <li>3. Restart the printer.</li> </ol>		<ol style="list-style-type: none"> <li>1. Turn on the printer, and then press the Ethernet card <b>RESET</b> button for 2 seconds.</li> <li>2. Restart the printer.</li> </ol>
			

## 9. Reboot Ethernet Card

When the Ethernet card is not functioning normally, we can restore its default settings by following these steps:

1. Turn off the printer and remove all the printer covers.
2. Press and hold the **RESET** button, then turn on the printer. After 3 seconds, release the **RESET** button. At this time, the Ethernet card enters the **boot loader** mode and only the Green LED lights on.
3. You can check whether the Ethernet card enter the boot loader or not by sending the DOS command – **ping 192.168.1.100**.

```
C:\>ping 192.168.1.100
Pinging 192.168.1.100 with 32 bytes of data:
Reply from 192.168.1.100: bytes=32 time<1ms TTL=64
Reply from 192.168.1.100: bytes=32 time<1ms TTL=64
Reply from 192.168.1.100: bytes=32 time<1ms TTL=64
Reply from 192.168.1.100: bytes=32 time<1ms TTL=64

Ping statistics for 192.168.1.100:
    Packets: Sent = 4, Received = 4, Lost = 0 (0% loss)
    Approximate round trip times in milli-seconds:
        Minimum = 0ms, Maximum = 0ms, Average = 0ms

C:\>_
```

4. Download the Ethernet card firmware by entering **tftp -i 192.168.1.100 put ARGOX\_v0.71**. Wait for 40 seconds to let the Ethernet card automatically restart or until the Amber LED blinks and the Green LED lights on. (**ARGOX\_v0.71** is the Ethernet card firmware and it should be placed at the corresponding working directory).

```
C:\>tftp -i 192.168.1.100 put argox_v0.71
Transfer successful: 1814540 bytes in 1 second, 1814540 bytes/s
```

## 10. Ethernet Card Replacement

### 10.1 A-2240E Ethernet Card Replacement

1. Turn off the printer.
2. Remove the 2 screws (I) on the bottom of the printer (39).
3. Pull out the front side of the “Middle Cover” (27) then remove it from “Bottom” (39) as shown in Fig. 10.1.1.
4. Remove the “Middle Cover” (27).

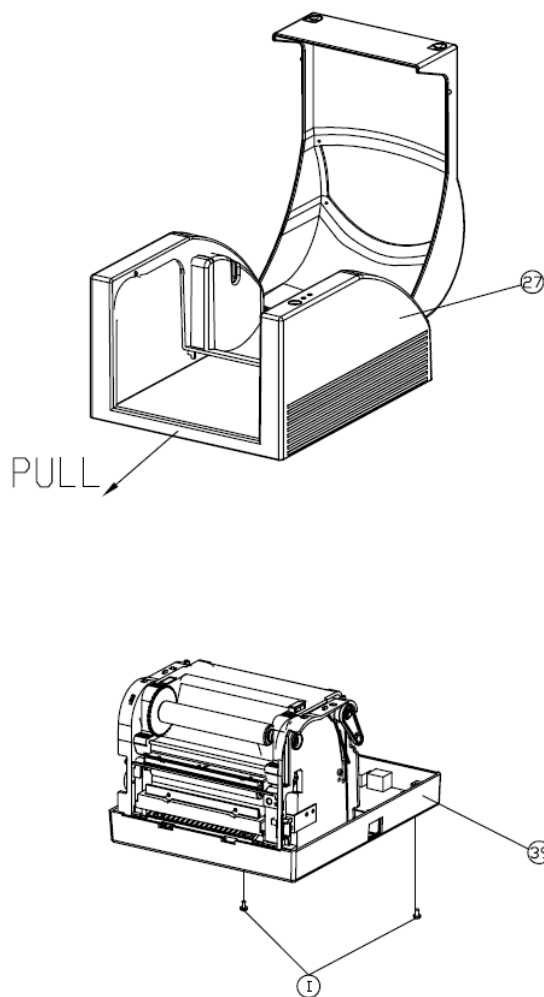

Figure 10.1.1



5. Remove the 4 screws (E).
6. Unplug all the connectors that are connected on the main board. Then remove the “Printer Chassis” (30) as shown in Fig. 10.1.2.

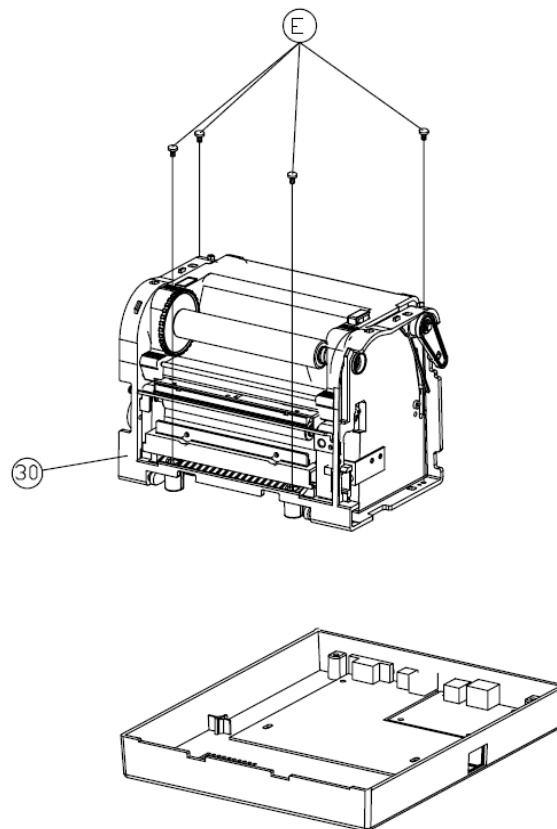

Figure 10.1.2

7. Remove the 4 screws (B) which fix the main board (43) from the bottom (39). Then remove the defected main board as shown in Fig. 10.1.3.

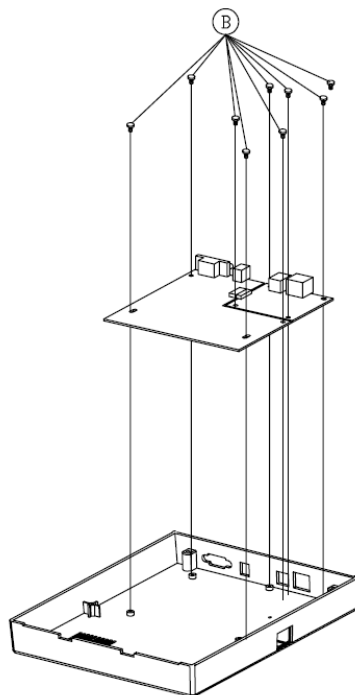

Figure 10.1.3

- Pull out the Ethernet card (93) from the main board, and then insert the new Ethernet card (93) to main board as shown in Fig. 10.1.4.

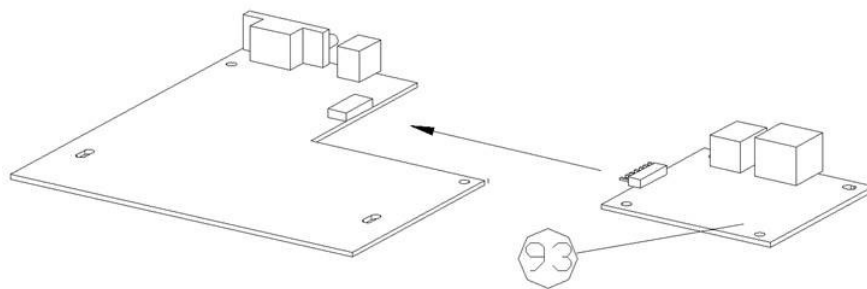

Figure 10.1.4

- Secure the 4 screws (B) to fix the main board.
- Secure the 4 screws to fix the "Printer Chassis" (30) to the bottom (39).
- Secure the 2 screws (I) to the printer bottom.
- Press and click "Power Switch" on the switch hole located on the "Middle Cover" (27).

## 10.2 X-2300E/X-3200E Ethernet Card Replacement

- Switch off the power and disconnect the AC power cord.
- Open the left side cover of the printer.
- Remove the 2 screws on the centronics (Fig. 10.2.1).

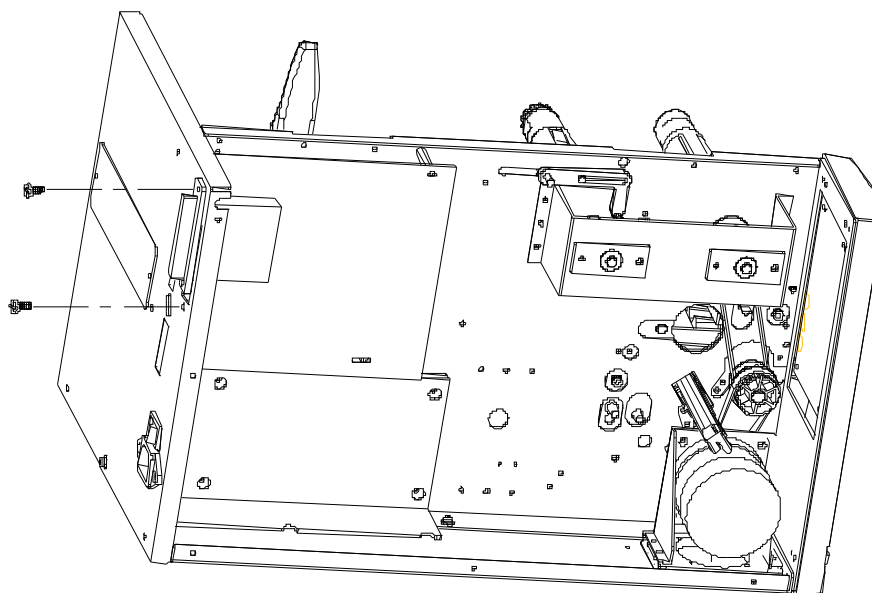
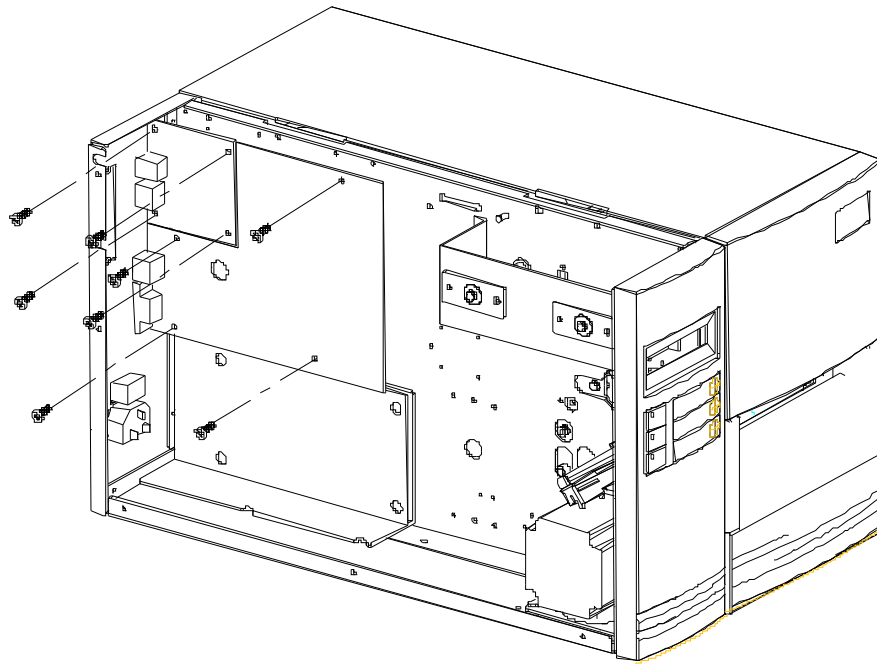

Figure 10.2.1

4. Remove the 8 screws on the main board (Fig. 10.2.2).



**Figure 10.2.2**

5. Replace the Ethernet card on the main board (Fig. 10.2.3).

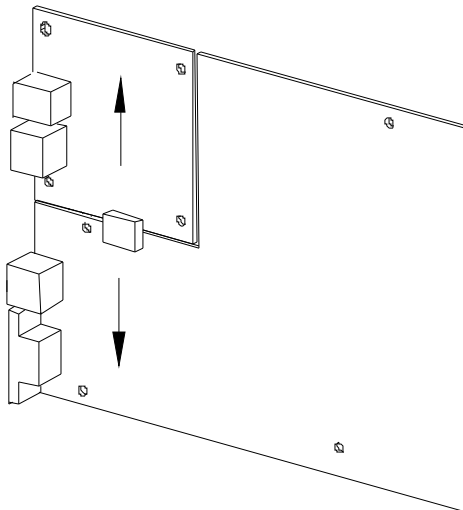

**Figure 10.2.3**

## 10.3 CP-2140E Ethernet Card Replacement

1. Turn off the printer.
2. Remove the 2 screws (J) on the printer bottom (71).
3. Pull out the front side of the “Middle Cover” (3) then remove it from “Bottom” (71) as shown in Fig. 10.3.1.
4. Remove the “Middle Cover” (3).

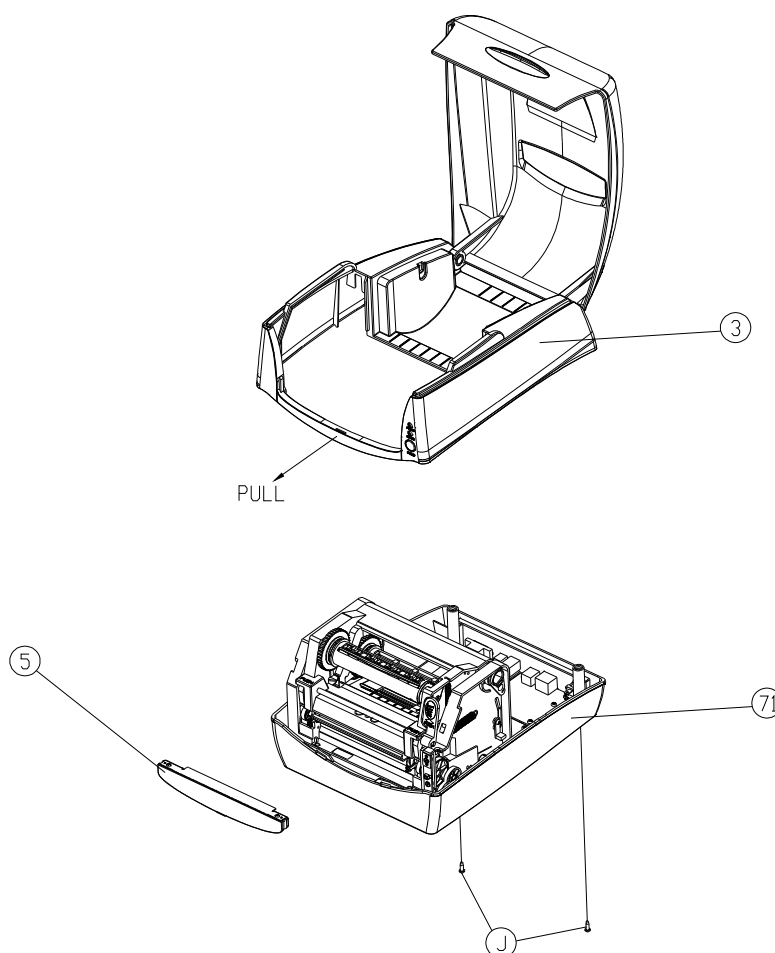
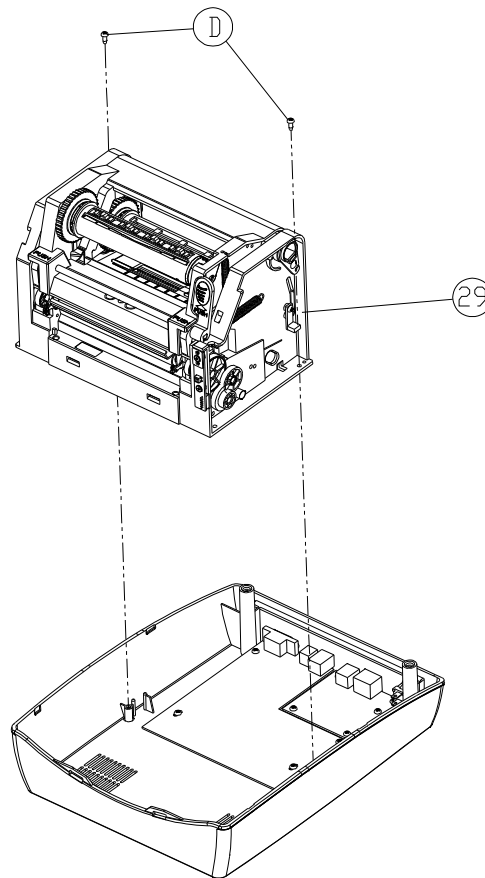

Figure 10.3.1

5. Remove the 2 screws (D).
6. Unplug all the connectors that are connected to the main board. Then remove the “Printer Chassis” (29) as shown in Fig. 10.3.2.



**Figure 10.3.2**

7. Remove the 8 screws (D) which fix the main board (69) from the bottom (71). Then remove the defected main board as shown in Fig. 10.3.3.

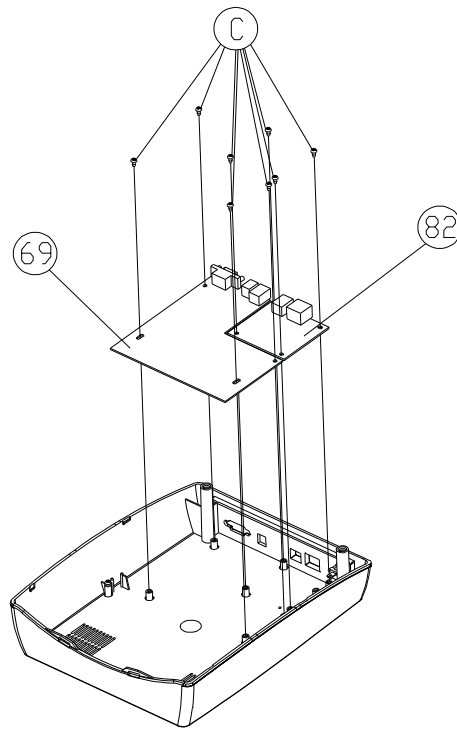

**Figure 10.3.3**

8. Remove the Ethernet card (82) from the main board, and then insert the new Ethernet card (82) to the main board as shown in Fig. 10.3.4.

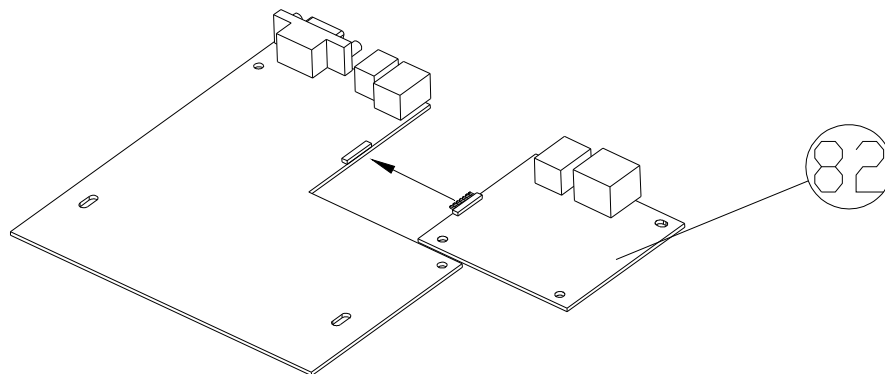
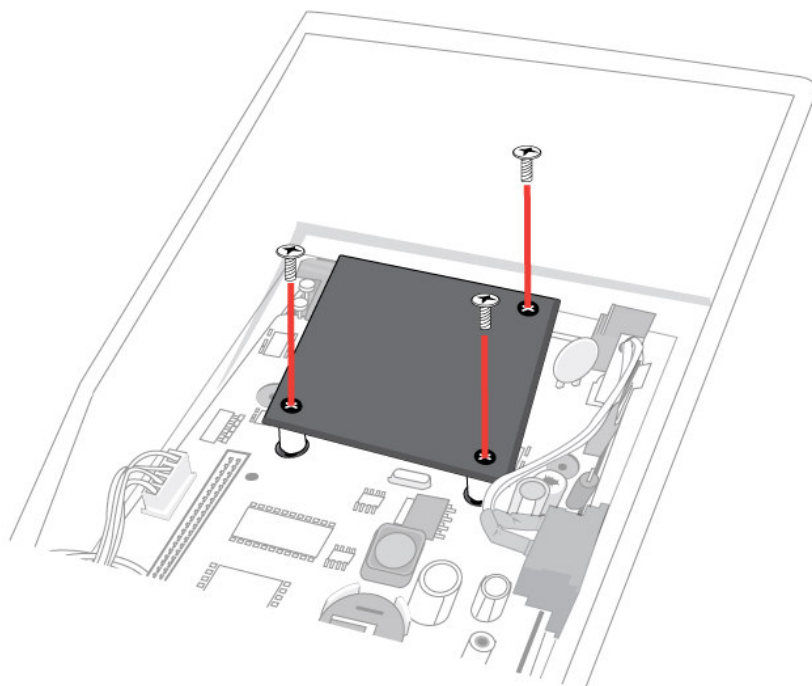

**Figure 10.3.4**

9. Secure the 8 screws (C) to fix the main board.
10. Secure the 2 screws (D) to fix "Printer Chassis" (29) to the bottom (71).
11. Secure the 2 screws (J) on the bottom of the printer.
12. Press and click "Power Switch" on the switch hole located on the "Middle Cover" (3).

## 10.4 OS-2130DE Ethernet Card Replacement

1. Turn off the printer power; unplug the power cable and the USB/Ethernet/Serial cable.
2. Remove the top cover.
3. Remove the 2 screws on the base housing.
4. Remove the whole print head assembly by releasing the 4 screws on its feet.
5. Remove the 3 screws which fix the Ethernet card as shown in the illustration below.



**Figure 10.4.1**

6. Place the new Ethernet card to its original position.
7. Secure the 3 screws to fix the Ethernet card.
8. Secure the 4 screws to fix "Printer Chassis" to the bottom.
9. Secure the 2 screws on the bottom of the printer.
10. Press and click "Power Switch" on the switch hole located on the "Middle Cover".

## 11. Printer Utility

### 11.1 Download/Upgrade firmware

1. Choose the printer that you want to upgrade firmware or send files, then select **LAN** on the **Interface** option.

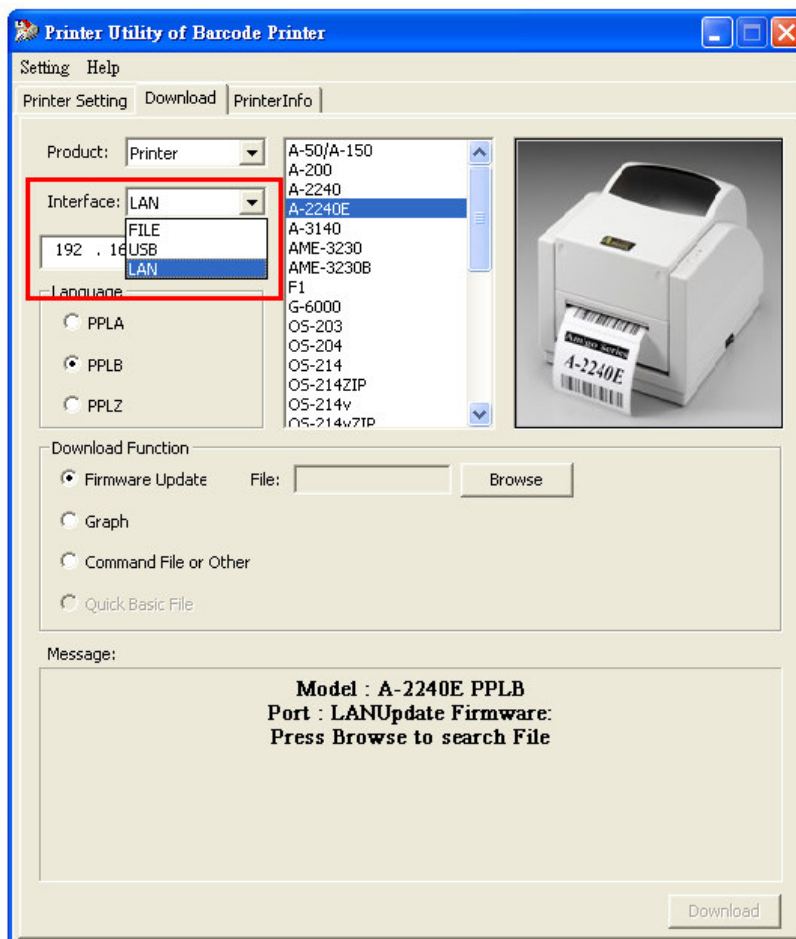



2. Enter the IP address. Now, you can upgrade firmware or send files similar with other printer operations.

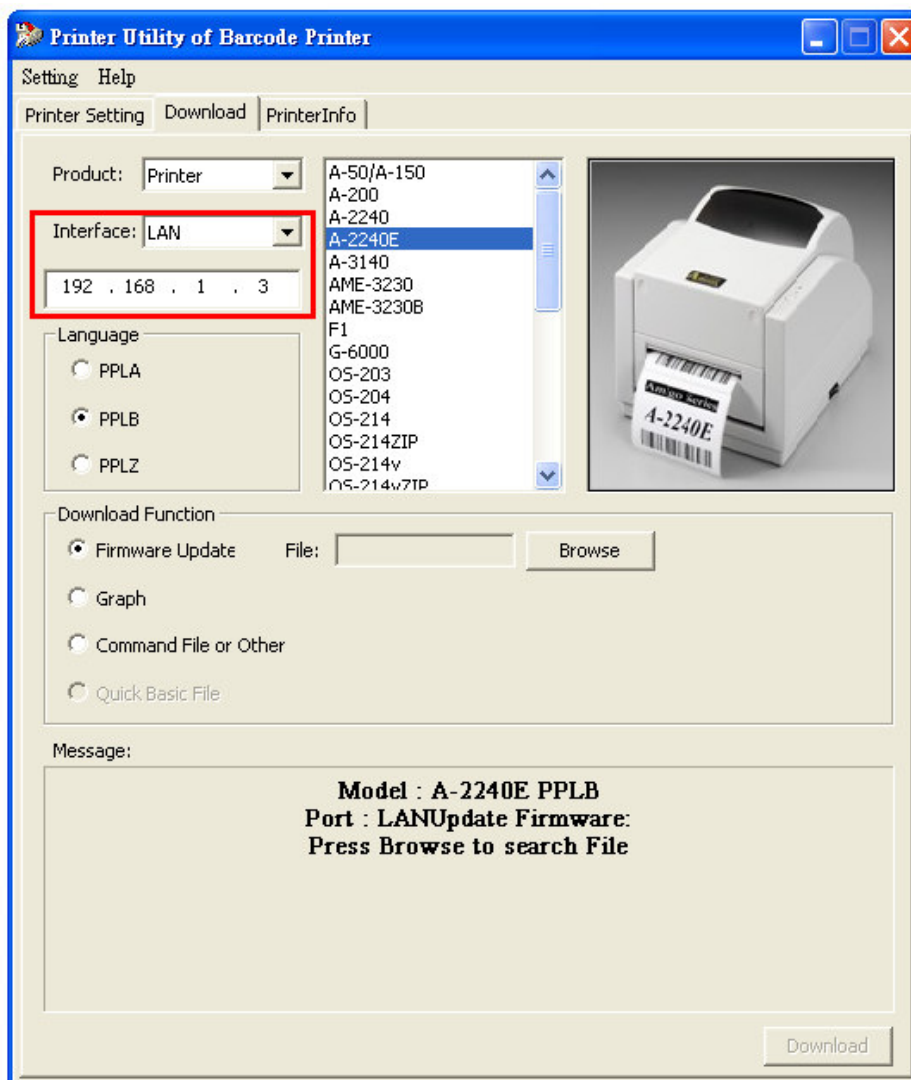

### 11.2 Printer setting

If there an error occurs, the computers will simultaneously receive the error message via the Router. (Fig.11.2.1)

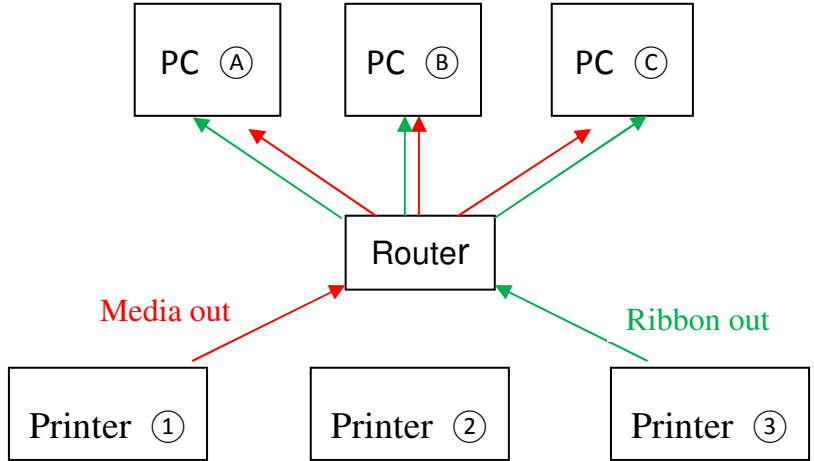

Fig.11.2.1

If the printer is directly connected to the PC using the Internet cable (the IP address must be set first), turn on the printer. The printer will search the IP address automatically, and it will be ready to print after 1 minute. (Fig.11.2.2)

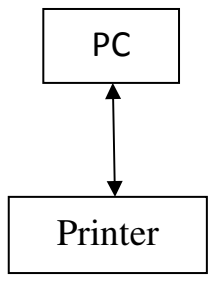
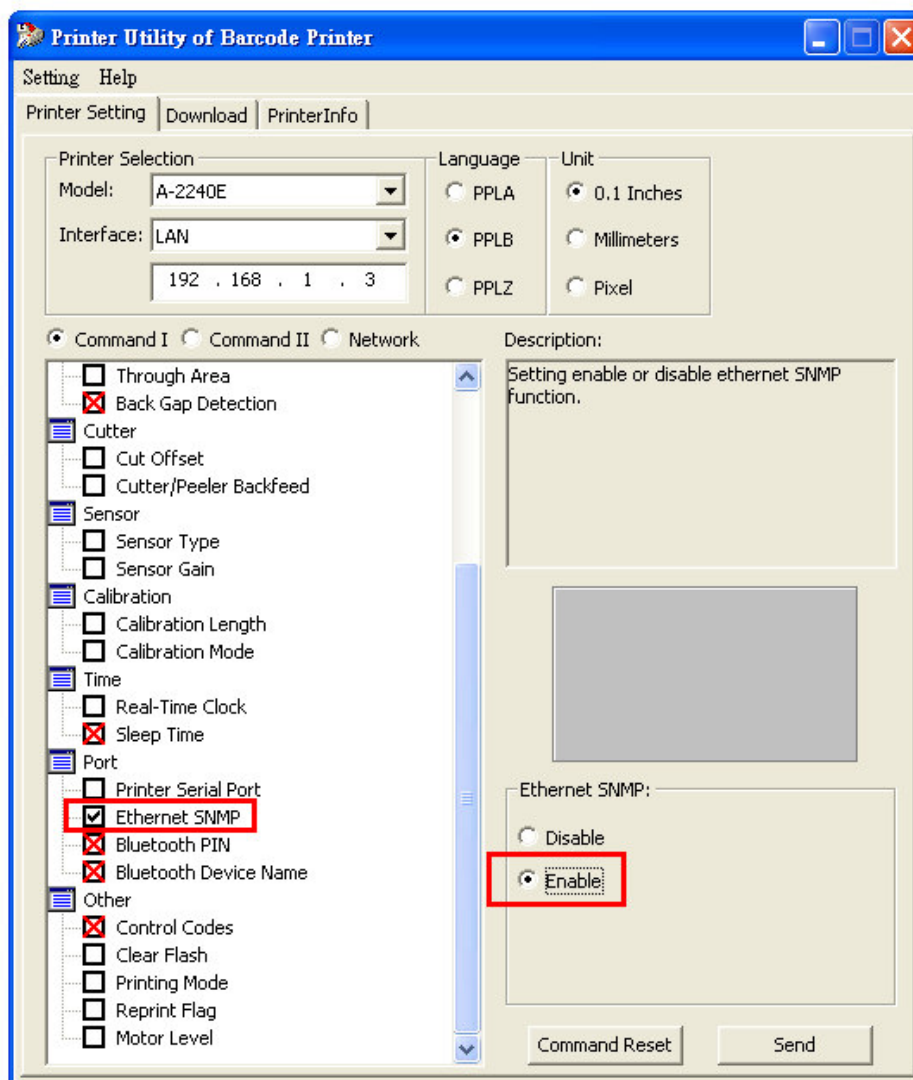

Fig.11.2.2

To enable the SNMP function, select **Ethernet SNMP** on **Port** option.



- The format of the printer status or the error code response through SNMP are as follows:

This format has 8 bytes. (0x00,0x00,0x00,0x00,0x00,0x00,0x00,0x00)	
HEX	Error message description
0x01	Power on
0x02	Media out
0x03	Ribbon out
0x04	Printer busy
0x05	Pause error(peeler pause)
0x06	Memory overflow
0x07	Cutter fail
0x08	TPH open
0x09	TPH too hot
0x0a~0x2f	Argox define
0x30~0x7F	User define
0x80~0xFF	Other define
<p><b>Example 1:</b> If the media out occurs and the printer responds "0x01 0x01"; that indicates 1 media out error has occurred.</p> <p><b>Example 2:</b> If the TPH is too hot and it is opened at the same time, the printer responds "0x02,0x08,0x09"; that indicates 2 errors have occurred. The errors are TPH too hot and TPH open.</p>	

## 11.3 Printer Info

1. Click the **Search Net Printer** button. On the **Printer Info** tab, the printer IP address is displayed.

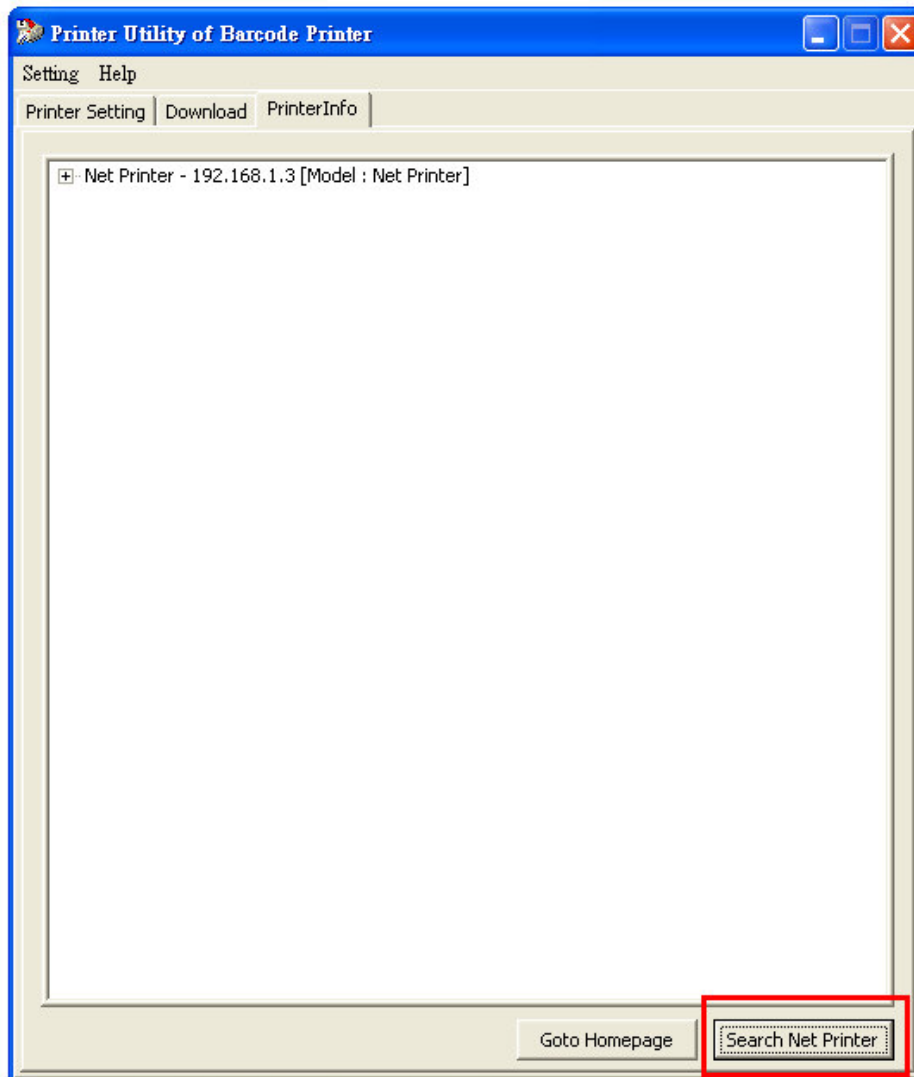

- 2. To display more information about the net printer, click the “+” on the **Net Printer**.  
Click the **Go to Homepage** button.

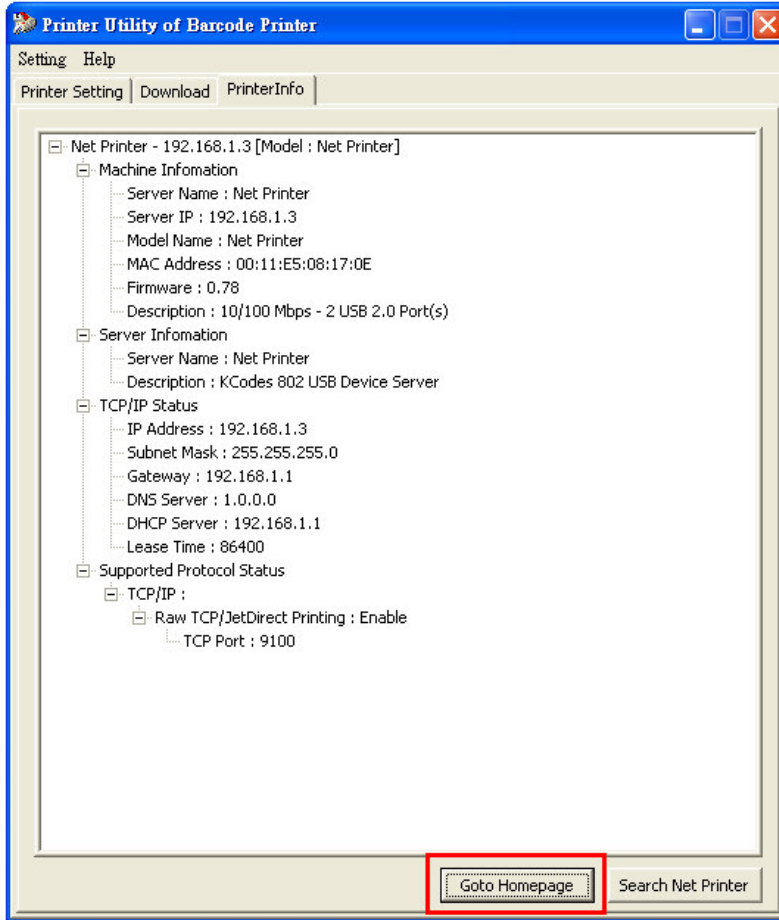

- 3. The webpage below appears on the screen.

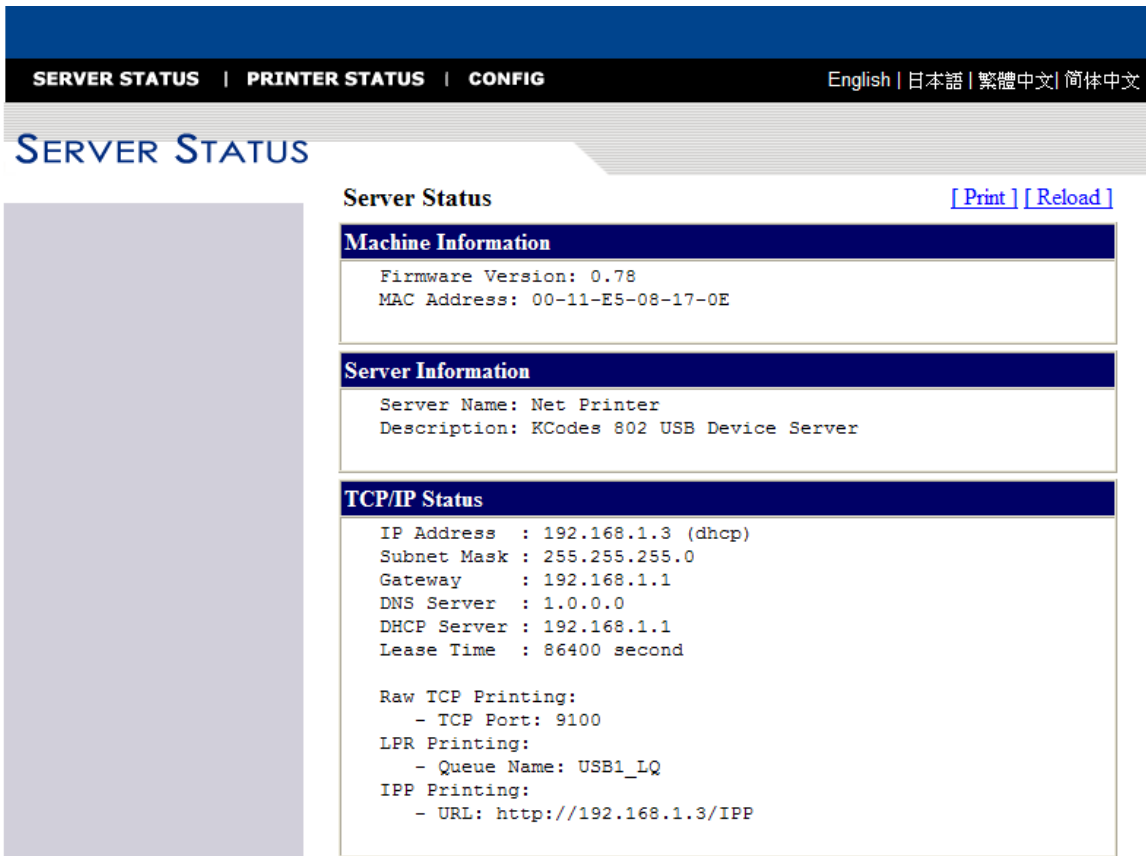

## 12. SELF-TEST DIAGNOSIS

### 12.1 Perform Self-test Diagnosis

When the printer is first installed, a self test should be performed. To perform the self test, please follow the below procedures:

- Turn off the power.
- Load the media (and ribbon, if using thermal transfer media instead of direct thermal paper) properly.
- Press and hold the **FEED** key, and then turn on the power.
- Release the **FEED** key after the printer starts to print.
- The configuration report should be printed as **Figure 12.1**.
- To return the printer to its normal operation, please turn off the power and turn on the power again or press the **CANCEL** key for one second. Otherwise, the printer will enter dump mode, and all input data will not be interpreted.

Contents and Information of A-2240E “PPLZ Self Test Label” are as follows:

#### 1. Printer Version Information

Displays the printer firmware version and date information.

#### 2. Standard RAM Size

Displays the standard RAM size of the printer.

#### 3. Available RAM Size

Displays the available memory that can be used to store the downloadable graphics, forms and soft fonts.

#### 4. Flash Type

Displays the flash type used in the printer.

#### 5. Available Flash Size

Displays the available flash capacity that can be used to store the downloadable graphics, forms and soft fonts.

#### 6. Int. fonts

Displays the Asian font types downloaded to the printer.

**7. H. position adjust**

Sets the horizontal offset when printing.

**8. Sensor type**

Displays sensor type in use - See-Through or Reflective.

**9. Label-less Calibration Value**

Checks whether the printer performs a label-less calibration or not. If not, it should be 0000.

**10. Check Sum**

Used to check whether the firmware flash is correct or not. It should be 0000.

**11. Max Label Height**

Displays the maximum printing label height.

**12. Print Width**

Displays the print width.

**13. Label Length**

Displays the height of the label size.

**14. Speed**

Displays the printer speed.

**15. ABS. Darkness**

Displays the ABS darkness level.

**16. Trim. Darkness**

Trims the darkness level.

**17. Print Mode**

Sets the print mode: TT (Thermal Transfer with ribbon) mode or DT (Direct Thermal without ribbon) mode.

**18. Print Length Meter**

Displays the length printed in meters. With this information, you may check the print head warranty. The value will not be reset even if you replace the TPH or any other components.



**19. Cut Count**

Displays the amount of labels that the printer cuts off.

**20. RS232 Protocols**

Displays the data frame of the RS-232 interface: baud rate, parity, data bit, and stop bit.

**21. Control Character**

Displays the caret, delimiter and tilde control characters.

**22. Font Symbol Set**

Sets the symbol set of fonts.

**23. Media Type**

Displays the media type.

**24. Reprint After Error**

Displays the setting of the **Reprint After Error** is disabled/enabled.

**25. Backfeed Disable/Enable**

Enables or disables backfeed when printing.

**26. Cutter Disable/Enable**

Enables or disables cutter when printing.

**27. Peeler Disable/Enable**

Enables or disables peeler when printing.

**28. Calibration Type Mode**

Sets the type of the calibration mode that is used. There are four types of calibration modes.

**29. Ethernet Module Version Information**

Displays the Ethernet Module version.

**30. IP Address**

Displays the IP address to be assigned for PC.

**31. Subnet Mask**

Displays the subnet mask address. Subnet mask is logically visible, distinctly addressed part

of a single Internet Protocol network.<sup>[1]</sup> The process of sub netting is the division of a computer network into groups of computers that have a common, designated IP address routing prefix.

### 32. Gateway

Displays the gateway address. Gateway is a point of entry or exit at which a gate may be hung.

### 33. MAC Address

Displays the MAC address. MAC address is a unique identifier assigned to most network adapters or network interface cards (NICs) by the manufacturer for identification, and used in the Media Access Control protocol sub-layer.

### 34. SNMP

(Please refer to [11.2. Printer setting](#))

### 35. DIP switch

Sw2	ON	OFF
1	Idle	Idle
2	DT mode	Normal
3	Factory test	Normal
4	Idle	Idle
5	Add on card	Normal

### 36. Font Image

Used to check whether the Internal Fonts are correct or not.

```

Label Printer with Firmware → 1
A2240-201.02 020510
STANDARD RAM: 8 M BYTES → 2
AVAILABLE RAM: 5724K BYTES → 3
FLASH TYPE:ON BOARD 4M BYTES → 4
AVAILABLE FLASH: 2047K BYTES → 5
Int. fonts:NO ANY INTERNAL FONTS → 6
H. POSITION ADJUST.: 0000 → 7
SEE-THRU SENSOR(NORMAL) → 8
REF:3FE6 SEE:1318 SEE2:3298 → 9
CHECKSUM: 0000 → 10
MAX LABEL HEIGHT: 100 INCHES → 11
PRINT WIDTH: 800 → 12
LAB LEN(TOP TO TOP): 10 mm. → 13
SPEED: 2IPS → 14
ABS.Darkness:16 → 15
Trim.Darkness:0 → 16
DIRECT THERMAL → 17
PRINT LENGTH METER: 0 M → 18
CUT COUNT: 0 → 19
RS232: 9600, 8, N, 1P. XON/XOFF. → 20
CARET CONTROL CHAR :<^> 5EH → 21
DELIMITER CONTROL CHAR:<, > 2CH → 21
TILDE CONTROL CHAR :<~> 7EH → 21
CODE PAGE : USA1 → 22
MEDIA : CONTINUOUS → 23
REPRINT AFTER ERROR : DISABLED → 24
BACKFEED ENABLE → 25
CUTTER DISABLE → 26
PEELER DISABLE → 27
CALIBRATION TYPE: MODE 1 → 28
Ethernet version: 0.80 → 29
IP_address: 192,168,1,100 → 30
Subnet_mask: 255,255,255,0 → 31
Gateway: 192,168,1,100 → 32
MAC_address: 00-11-E5-01-32-A5 → 33
SNMP: DISABLE → 34
s( 0 ,0 )
U4,0,0,0,0,52480
0,0,0,0,0,0,1,1,1,1,
 1 2 3 4 5 DIP SWITCH → 35

THIS IS FONT A. 0123ABCabc
THIS IS FONT B. 0123ABCABC
THIS IS FONT C. 0123ABCabc
THIS IS FONT D. 0123ABCabc
THIS IS FONT E. 0123ABCabc
THIS IS FONT F. 0123ABCabc
THIS IS FONT G.
THIS IS FONT H. 0123ABC
This Is Font CG Triumv Bd Condensed.

```

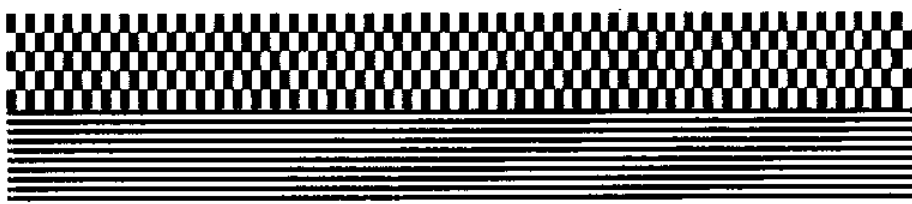

Figure 12.1.