



Hand Sanitizer Kiosk

KHD-N100

Great useful in high-traffic public places

- Hospital
- Catering
- Shopping Mall
- School
- Hotel
- Building
- Supermarket



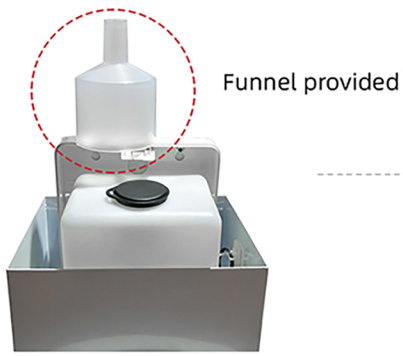

Funnel provided

Internal Storage Volume:
1200ML—provides 1000 pumps



Auto dispenser

Front View

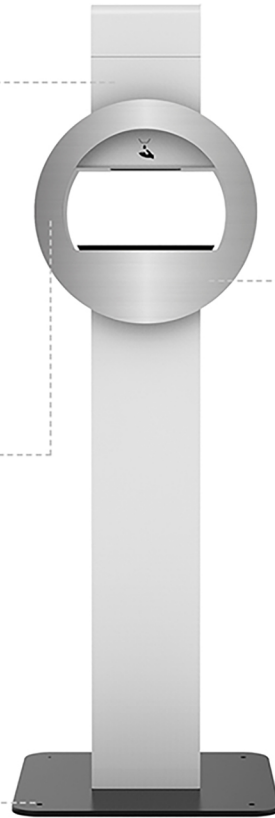

Stainless steel panel



Heavy base

Back View

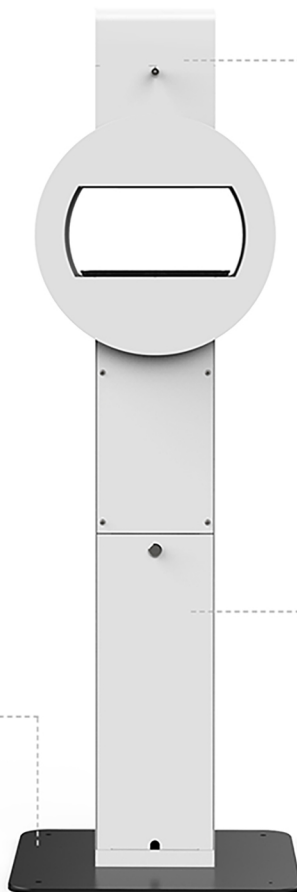

Lockable Top Case



Cable Compartment

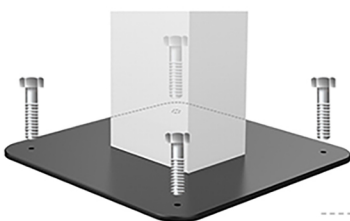

Drilling mounting



Leak-proof design

SPECIFICATIONS

Unit:mm

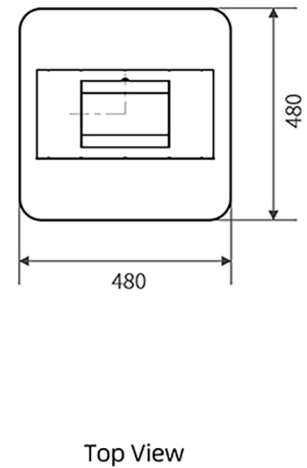
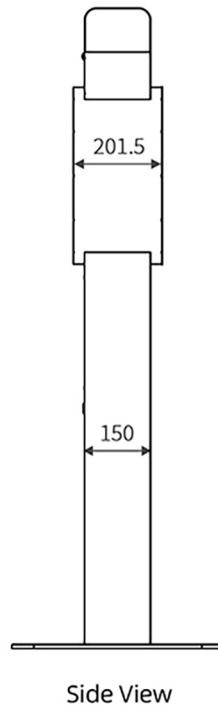
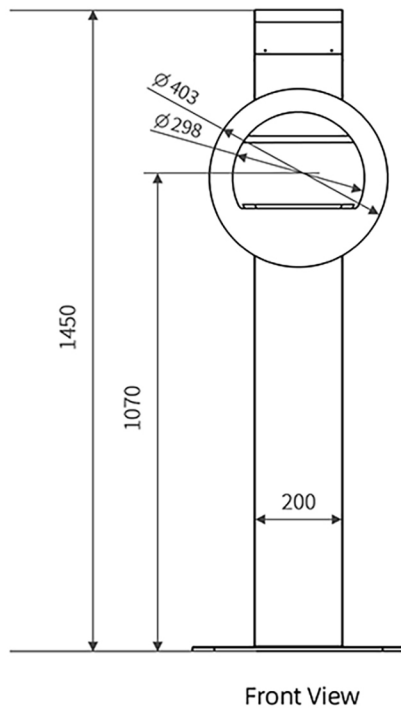

Information

Model

KHD-N100

Dimensions (mm)

L480×W480×H1450

Dimensions (inch)

W18.9×D18.9×H57.1

Net Weight

45kg

Material

SPCC, Stainless steel panel

Color

White

Customization

Color