

Hand Sanitizer Kiosk

KHD-2100

Great useful in high-traffic public places

- Hospital
- Catering
- Shopping Mall
- Hotel
- Building
- School
- Supermarket





21.5 inch HD display screen

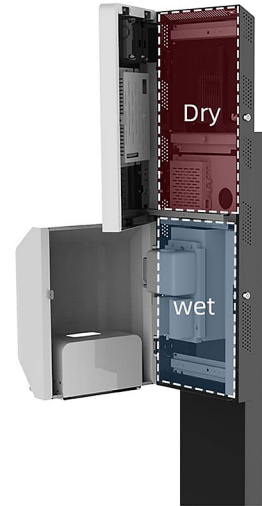
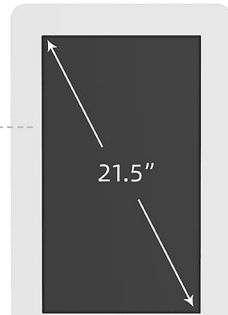

Dry and wet separation



Auto dispenser

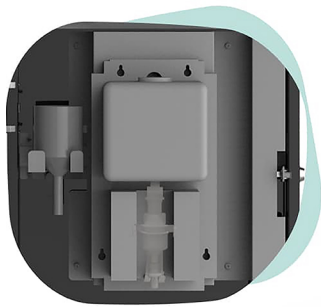

1200ML volume provides 1000 pumps



Solid stand and heavy base



Brand It
as your need



SPECIFICATIONS

Unit:mm

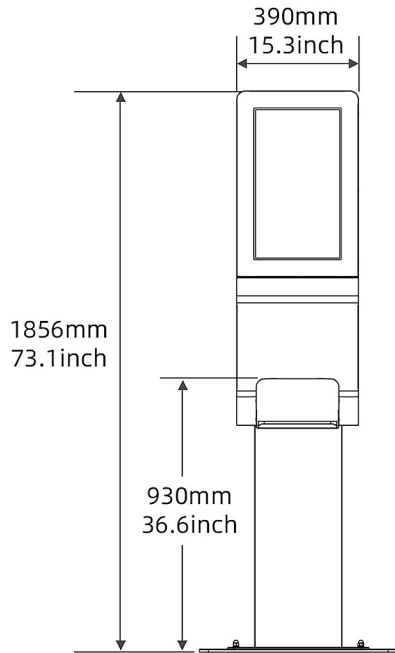

Front View

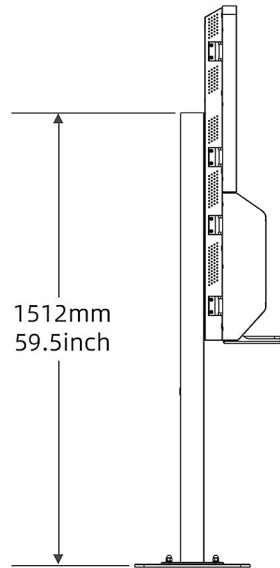

Side View

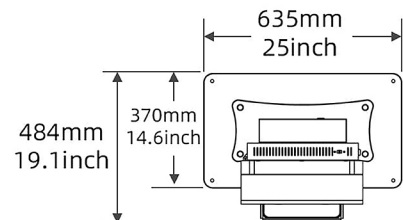

Top View

Internal Storage Volume:

1200ML—provides 1000 pumps

OS System	WIN 10 (trial version)	Android 7.1
CPU	Intel Celeron J1900 quad-core 2.0G	RK3288 Cortex-A17 quad-core 1.8GHz
System Memory	4G	2G/4G
Disk	64G/128G/256G(SSD)	8G/16G/32G/64G
Interface	USB*8/RJ45*1	USB*6/RJ45*1

Panel Size: 21.5 inch LCD
Display Ratio: 16:9
Max Resolution: 1920×1080
Display Color: 16.7M
Brightness: 300cd/m²
Contrast Ratio: 3000:1
Viewing Angle: H178° V178°
Response Time: 18ms
Refresh Rate: 60Hz
Panel Life: 30000 hours

Material: SPCC
Color: Pictured, or customized
Speaker: 5W*2
Supports Internet: Ethernet/WIFI
Power Supply: 100-240VAC,50/60HZ
Power Consumption: <50W
Working Temperature: 0~40°C
Storage Temperature: -20~60°C
Working Humidity: 20%~80%
Storage Humidity: 10%~90%
Application: Indoor



Inter-Register Communication (M) Sdn. Bhd. [198701004225 (162895-K)]

34, Jalan Tanjung SD 13/1, Bdr Sri Damansara,

52200 Kuala Lumpur.

Tel: (6)03-6272 8000 (8 Line) Fax: (6)03-6272 3210

general@irc.com.my

www.irc.com.my

Authorise Resslerer :