

KF-1900C

19" Countertop Information Kiosk

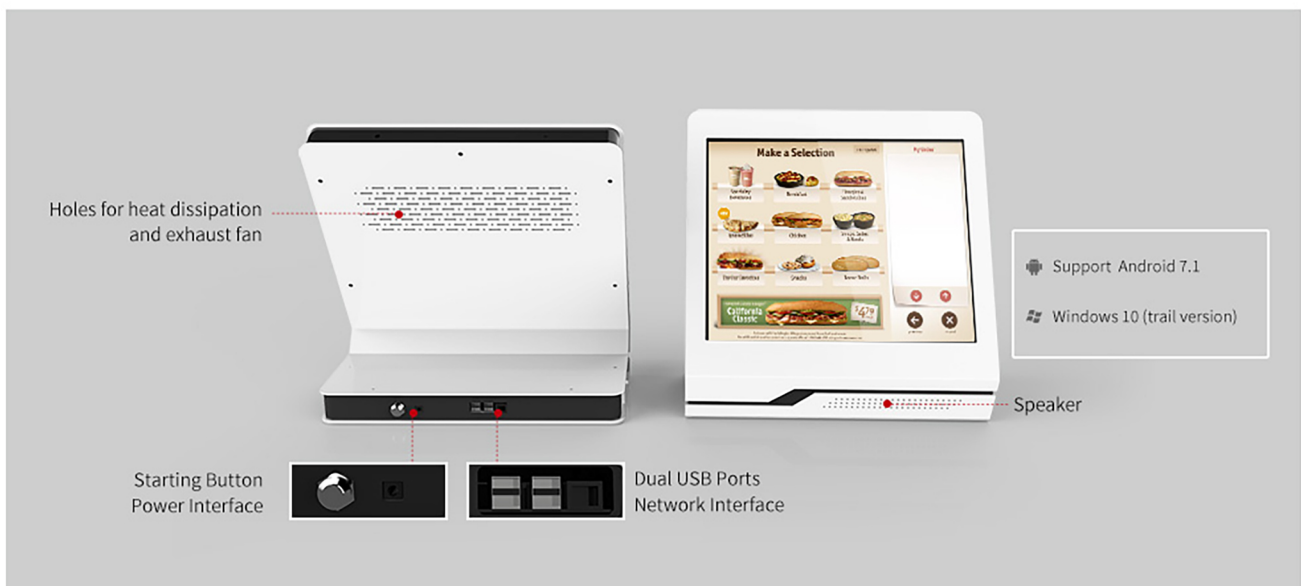

FEATURES





- The multi-point infrared touch technology support powerful interactive features and applications are wider.



- Designed with two - channel speakers



- Holes for heat dissipation

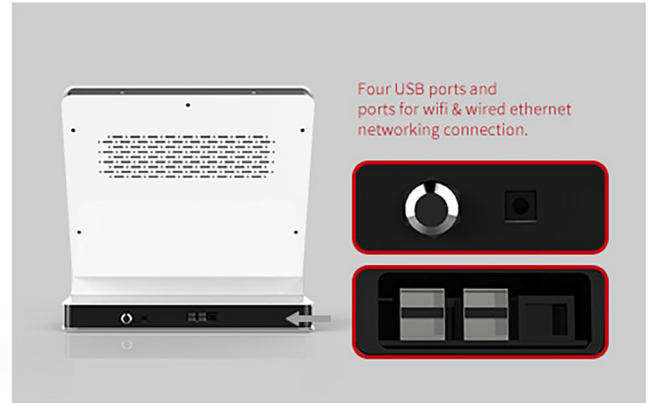

- For additional ports can be customized

APPLICATIONS



SPECIFICATIONS

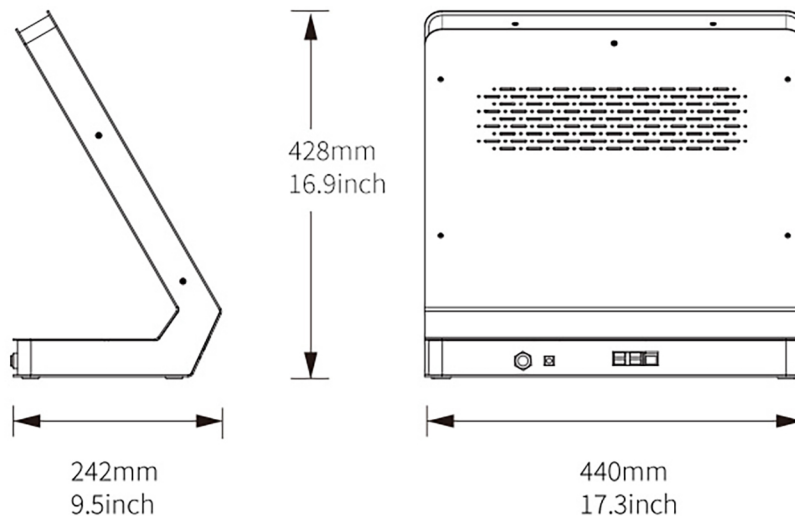

OS Support	WIN 10 (trial version)	Android 7.1	
CPU	Intel Celeron J1900 qual-core 2.0G	RK3288 Cortex-A17 quad-core 1.8GHz	
System Memory	4G	2G/4G	
Disk	64G/128G/256G(SSD)	8G/16G/32G/64G	
Speaker	5W*2	5W*2	
Interface	USB*4/RJ45*1	USB*2/RJ45*1	
Network	Ethernet/WIFI		
Touch screen			
Type	Projective Capacitive Touch (10 points)	Response time	10ms
LCD			
Type	TFT-LCD	Contrast Ratio	1000:1
Screen size	19"	Response time	5ms
Max Resolution	1280x1024	Viewing angle	H178° V178°
Aspect Ratio	5:4	Display Colors	16.7M
Brightness	250cd/m ²	Refresh Rate	60Hz
Panel Life	30000 hours		
Power			
Voltage	100-240VAC,50/60Hz	Power Consumption	<40W
Enclosure			
Material	SPCC	Surface	Powder coated
Overall size	L440 x W242 x H428mm	Color	White, black or customized
Net weight	13.8kg		
Application			
Working temperature	0~40°C	Storage temperature	-20~60°C
Working humidity	20%~80%	Storage humidity	10%~90%
Application	indoor		

Assembly & Installation

Operating Instructions

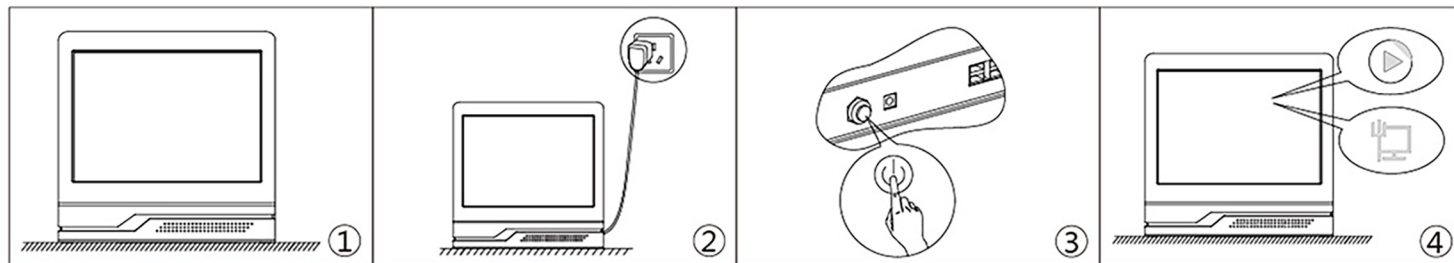

- Place ordering kiosk at desired location.
- Connect the power cord and the internet cable.
- Press the starting button for booting.
- Install the multimedia playing terminal software, set the network parameters.
Mark: Support timer switch, remote shutdown and wake on LAN.

Packing List



Product
x1

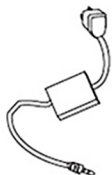

Power Cord
x1



User Manual
x1